

Operating Instructions

**Copy
Printer Reference
Scanner**

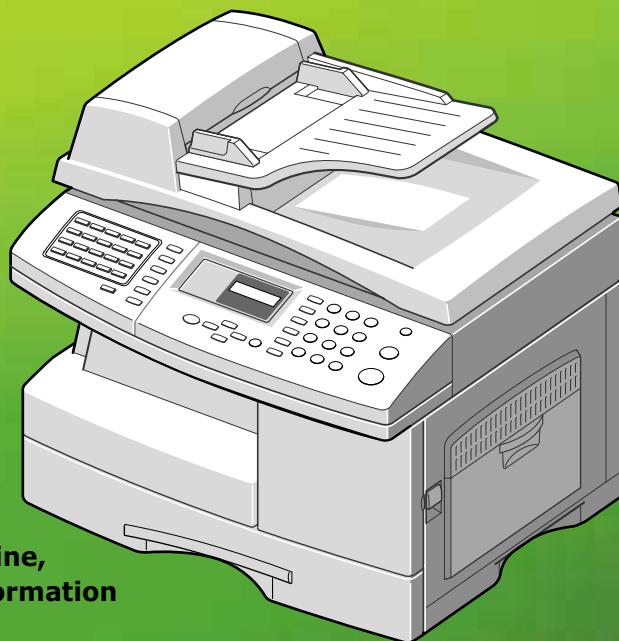

**For safe and correct use of this machine,
please be sure to read the Safety Information
in this manual before you use it.**

About the Operating Instructions

Your machine comes with the two References:

Copy/Printer/Scanner Reference provides information you need for setting up your machine and installing the supplied software. It also provides all of the detailed instructions for using your machine as a printer, a scanner and a copier and information for maintaining and troubleshooting the machine.

Facsimile Reference provides information for using your machine as a fax machine. You can find how to send and receive a fax, and how to set fax-related options.

Contents of this manual are subject to change without prior notice. In no event will the company be liable for direct, indirect, incidental or consequential damages as a result of handling or operating the machine.

Copyright © 2004

- Centronics is a trademark of Centronics Data Computer Corporation.
- IBM and IBM PC are trademarks of International Business Machines Corporation.
- Microsoft, Windows, Windows 9x, Window Me, Windows 2000, Windows NT 4.0 and Windows XP are registered trademarks of Microsoft Corporation.
- All other brand or product names are trademarks of their respective companies or organizations.

Safety Information

When using this machine, the following safety precautions should always be followed.

Safety During Operation

In this manual, the following important symbols are used:

⚠ WARNING:

Indicates a potentially hazardous situation which, if instructions are not followed, could result in death or serious injury.

⚠ CAUTION:

Indicates a potentially hazardous situation which, if instructions are not followed, may result in minor or moderate injury or damage to property.

⚠ WARNING:

- **Connect the power cord directly into a wall outlet and never use an extension cord.**
- **Disconnect the power plug (by pulling the plug, not the cable) if the power cable or plug becomes frayed or otherwise damaged.**
- **To avoid hazardous electric shock or laser radiation exposure, do not remove any covers or screws other than those specified in this manual.**
- **Turn off the power and disconnect the power plug (by pulling the plug, not the cable) if any of the following occurs:**
 - **You spill something into the machine.**
 - **You suspect that your machine needs service or repair.**
 - **The external housing of your machine has been damaged.**
- **Do not incinerate spilled toner or used toner. Toner dust might ignite when exposed to an open flame.**
- **Disposal can take place at our authorized dealer.**
- **Dispose of the used toner bottle in accordance with the local regulations.**

⚠ CAUTION:

- *Protect the machine from dampness or wet weather, such as rain and snow.*
- *Unplug the power cord from the wall outlet before you move the machine. While moving the machine, you should take care that the power cord will not be damaged under the machine.*
- *When you disconnect the power plug from the wall outlet, always pull the plug (not the cable).*
- *Do not allow paper clips, staples, or other small metallic objects to fall inside the machine.*
- *Keep toner (used or unused) and toner bottle out of the reach of children.*
- *Be careful not to cut yourself on any sharp edges when you reach inside the product to remove misfed sheets of paper or masters.*
- *For environmental reasons, do not dispose of the machine or expended supply waste at household waste collection points. Disposal can take place at an authorized dealer.*
- *The inside of the machine could be very hot. Do not touch the parts with a label indicating the "hot surface". Otherwise, an injury might occur.*

Power Supply

The socket-outlet shall be installed near the product and shall be easily accessible.

Ozone Safety (if applicable)

Some product (see specification in the Operating Instructions) generates ozone during operation.

Normally, the ozone level is safe for operators. If ozone odor may appear, ventilate the room.

For Fax or Telephone

Do not use this product near water, for example, near a bathtub, wash bowl, kitchen sink or laundry tub, in a wet basement or near a swimming pool. Avoid using a telephone during an electrical storm. There may be a remote risk of electric shock from lightning. Do not use a telephone in the vicinity of a gas leak to report the leak.

For North America

CDRH Regulations

This equipment complies with requirements of 21 CFR subchapter J for class 1 laser products. This equipment contains a 5 milliwatt, 760–800 nanometer wavelength, AlGaAs laser diode. This equipment does not emit hazardous radiation, since the beam is totally enclosed during all customer modes of operation and maintenance.

Caution:

Use of controls or adjustment or performance of procedures other than those specified in this manual might result in hazardous radiation exposure.

Positions of Labels and Hallmarks for ⚠️ WARNING and ⚠️ CAUTION Labels

This machine has labels for ⚠️ WARNING and ⚠️ CAUTION at the positions shown below. For safety, please follow the instructions and handle the machine as indicated.

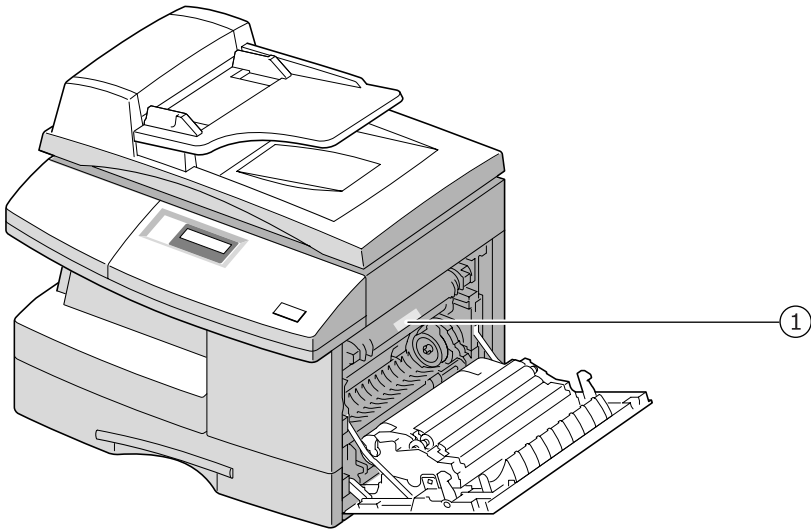

①



180°C
356°F

The inside of the machine could be very hot.
Do not touch the parts with a label indicating the "hot surface".
Otherwise it could cause a personal burn.

In accordance with IEC 60417, this machine uses the following symbols for the main power switch:

| means POWER ON.

○ means POWER OFF.

NOTICE

Note to users in the United States of America

Notice:

This equipment has been tested and found to comply with the limits for a Class A digital device, pursuant to Part 15 of the FCC Rules. These limits are designed to provide reasonable protection against harmful interference when the equipment is operated in a commercial environment. This equipment generates, uses and can radiate radio frequency energy and, if not installed and used in accordance with the instruction manual, may cause harmful interference to radio communications. Operation of this equipment in a residential area is likely to cause harmful interference in which case the user will be required to correct the interference at his own expense.

Warning

Changes or modifications not expressly approved by the party responsible for compliance could void the user's authority to operate the equipment.

Notice about the Telephone Consumer Protection Act (Valid in USA only).

The Telephone Consumer Protection Act of 1991 makes it unlawful for any person to use a computer or other electronic device, including FAX machines, to send any message unless such message clearly contains in a margin at the top or bottom of each transmitted page or on the first page of the transmission, the date and time it is sent and an identification of the business or other entity, or other individual sending the message and the telephone number of the sending machine or such business, other entity, or individual. (The telephone number provided may not be a 900 number or any other number for which charges exceed local or long-distance transmission charges.)

In order to program this information into your FAX machine, you should complete the following steps: Follow the FAX HEADER programming procedure in the Programming chapter of the operating instructions to enter the business identification and telephone number of the terminal or business. This information is transmitted with your document by the FAX HEADER feature. In addition to the information, be sure to program the date and time into your machine.

USA

◆ FCC Requirements

1. This equipment complies with Part 68 of the FCC rules and requirements adopted by the ACTA. On the cover of this equipment is a label that contains, among other information, a product identifier in the format US:AAAEQ##TXXXXX. If requested, this number must be provided to the telephone company.
2. This equipment uses the RJ11C USOC jack.
3. A plug and jack used to connect this equipment to the premises wiring and telephone network must comply with the applicable FCC Part 68 rules and requirements adopted by the ACTA. A compliant telephone cord and modular plug is provided with this product. It is designed to be connected to a compatible modular jack that is also compliant. See installation instructions for detail.
4. The REN is used to determine the number of devices that may be connected to a telephone line. Excessive RENs on a telephone line may result in the devices not ringing in response to an incoming call. In most but not all areas, the sum of RENs should not exceed five (5.0). To be certain of the number of devices that may be connected to a line, as determined by the total RENs, contact the local telephone company. The REN for this product is part of the product identifier that has the format US:AAAEQ##TXXXXX. The digits represented by ## are the REN without a decimal point (e.g., 03 is a REN of 0.3).
5. If this equipment causes harm to the telephone network, the telephone company will notify you in advance that temporary discontinuance of service may be required. But if advance notice is not practical, the telephone company will notify the customer as soon as possible. Also, you will be advised of your right to file a complaint with the FCC if you believe it is necessary.
6. The telephone company may make changes in its facilities, equipment, operations or procedures that could affect the operation of the equipment. If this happens the telephone company will provide advance notice in order for you to make necessary modifications to maintain uninterrupted service.
7. If trouble is experienced with this equipment, for repair or warranty information, please contact RICOH CORP. CUSTOMER SUPPORT DEPT. at 1-800-FASTFIX. If the equipment is causing harm to the telephone network, the telephone company may request that you disconnect the equipment until the problem is resolved.
8. In the event of operation problems (document jam, copy jam, communication error indication), refer to the solving problems section in this manual.
9. Connection to party line service is subject to state tariffs. Contact the state public utility commission, public service commission or corporation commission for information.

◆ WHEN PROGRAMMING EMERGENCY NUMBERS AND/OR MAKING TEST CALLS TO EMERGENCY NUMBERS:

1. Remain on the line and briefly explain to the dispatcher the reason for the call before hanging up.
2. Perform such activities in the off-peak hours, such as early morning hours or late evenings.

CANADA

The Ringer Equivalence Number is an indication of the maximum number of devices allowed to be connected to a telephone interface. The termination on an interface may consist of any combination of devices subject only to the requirement that the sum of the RENs of all the devices does not exceed five.

This product meets the applicable Industry Canada technical specifications.

Note:

This Class A digital apparatus complies with Canadian ICES-003.

CONTENTS

Chapter 1: **GETTING STARTED**

Unpacking	1.2
Component Location	1.4
Front View	1.4
Rear View	1.5
Control Panel Functions	1.6
Making Connections	1.9
Installing the Drum and Toner Cartridges	1.12
Turning the Machine On	1.15
Loading Paper	1.15
Tray Setting the Paper Size	1.19
Changing the Display Language	1.19
Using Save Modes	1.20
Paper Save	1.20
Power Save	1.20

Chapter 2: **INSTALLING SOFTWARE**

About the Software	2.2
System Requirements	2.3
Installing the Software	2.4
Removing Software	2.6

Chapter 3: **PAPER HANDLING**

Selecting Print Media	3.2
Paper Guidelines	3.3
TrayLoading Paper in the Tray	3.4
Using the Bypass Tray	3.6
Setting the Paper Size for Copying	3.9

Chapter 4: **COPYING**

Loading Paper for Copy Output	4.2
Selecting a Paper Tray	4.2
Making Copies from the Automatic Document Feeder	4.3
Making Copies using the Document Glass	4.4
Setting Copy Options	4.6
Image	4.6
Contrast	4.7
Set	4.7
Zoom	4.8
Auto Fit Copying	4.9
Clone Copying	4.10
Duplex Copying	4.11
Collation Copying	4.12

Chapter 5: **PRINTING**

Printing a Document	5.2
Printer Settings	5.3
Accessing Printer Settings	5.3
Printer Properties Tabs	5.4
Printing Multiple Pages on One Sheet of Paper (N-Up Printing)	5.6
Printing a Reduced or Enlarged Document	5.7
Fitting Your Document to a Selected Paper Size	5.8
Printing Posters	5.9
Using Watermarks	5.10
Using an Existing Watermark	5.10
Creating a Watermark	5.11
Editing a Watermark	5.12
Deleting a Watermark	5.12
Using Overlays	5.13
What is an Overlay?	5.13
Creating a New Page Overlay	5.13
Using a Page Overlay	5.15
Deleting a Page Overlay	5.16
Setting Graphic Properties	5.17
Printer Properties Buttons & Icons	5.20
Setting Up the Locally Shared Printer	5.20
In Windows 9x/Me	5.20
In Windows NT 4.0/2000/XP	5.21

Chapter 6: SCANNING

Scanning Process with TWAIN-enabled Software	6.2
--	-----

Chapter 7: MAINTENANCE

Cleaning the Scan Unit	7.2
Expected Cartridge Life	7.3
Replacing the Toner Cartridge	7.3
Setting to Notify Toner Low	7.7
Cleaning the Drum	7.8
Replacing the Drum Cartridge	7.8
Setting the machine to be Checked by Phone	7.11

Chapter 8: TROUBLESHOOTING

Document Jams	8.2
Input Misfeed	8.2
Exit Misfeed	8.3
Roller Misfeed	8.3
Paper Jams	8.4
Paper Feed Area	8.4
Fuser Area	8.6
Paper Exit Area	8.7
Duplex Jam	8.9
Bypass Tray Jam	8.10
LCD Error Messages	8.11
Solving Problems	8.13
Copier Problem Solution Chart	8.13
Printing Problem Solution Chart	8.15
Fax Problem Solution Chart	8.18

Chapter A: SPECIFICATIONS

General Specifications	A.2
Scanner and Copy Specifications	A.3
Printer Specifications	A.3
Facsimile Specifications	A.4

1

GETTING STARTED

Thank you for purchasing multifunctional product. This machine provides printing, copying, scanning, and faxing functions!

This chapter provides step-by-step instructions on setting up the machine, and installing the software.

This chapter includes:

- **Unpacking**
- **Component Location**
- **Control Panel Functions**
- **Making Connections**
- **Installing the Drum and Toner Cartridges**
- **Turning the Machine On**
- **Loading Paper**
- **Tray Setting the Paper Size**
- **Changing the Display Language**
- **Using Save Modes**

Unpacking

- 1 Remove the shipping tape from the front, back, and sides of the machine.

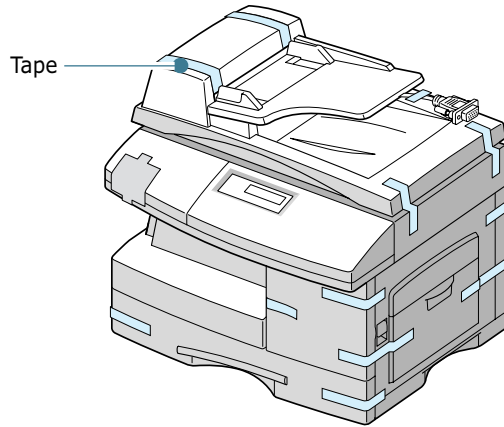

- 2 Remove the label completely from the scanner module by pulling it straight out, away from the unit. The scan unlock switch automatically moves to the unlock position (🔓).

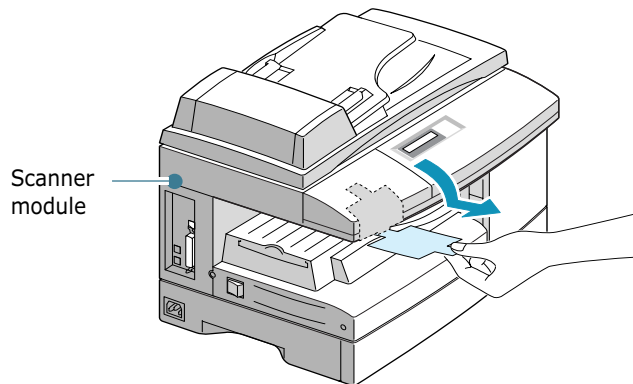

NOTE: To scan or copy a document, the switch must be on that position. When you are moving the machine or do not intend to use it for a long time, push the switch to the lock position (🔒).

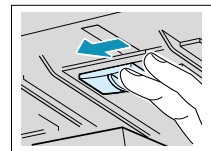

- 3 Pull open the paper Tray and remove the packing material from the paper Tray.

4 Ensure that you have the following:

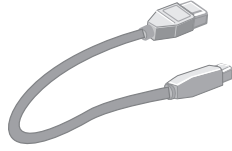

USB Cable

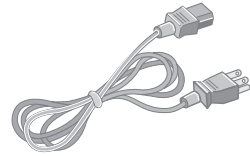

AC Power Cord

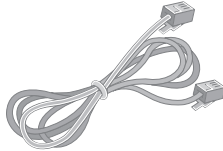

Telephone Line Cord

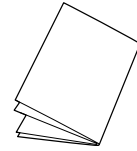

Quick install Guide

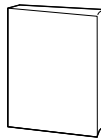

Quick Guide

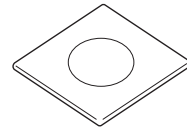

CD-ROM*

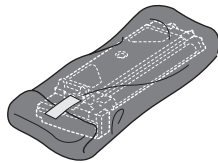

Toner Cartridge

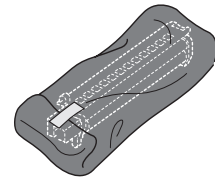

Drum Cartridge



Brand plaque**

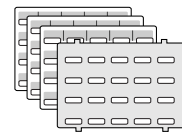

One-Touch sheet***

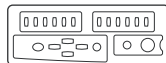

Key layout sheet***

*. The CD-ROM contains the Type 102 driver, Operating Instructions and the Adobe Acrobat Reader program.

** . May already be affixed to the machine in some regions.

***. May already be affixed to the machine .

Component Location

Take a moment to familiarise yourself with the main components of your machine.

Front View

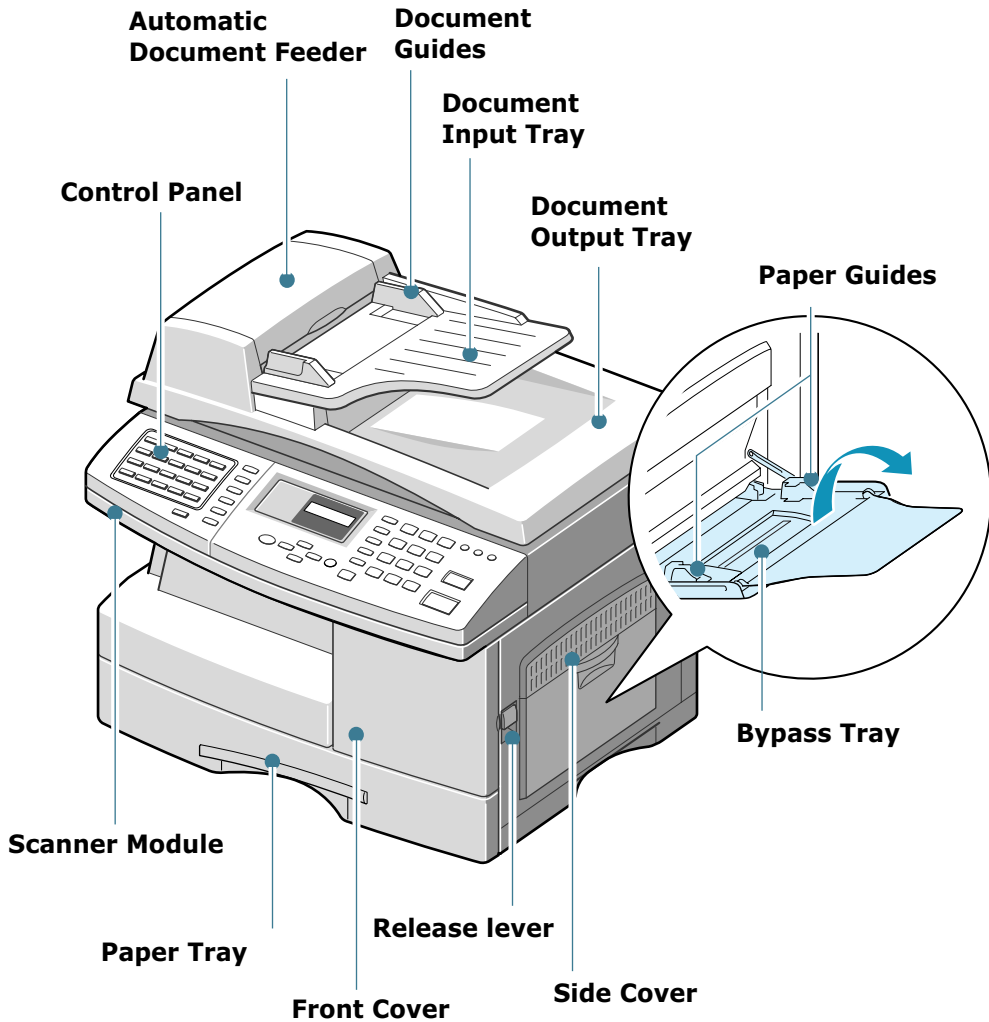

Rear View



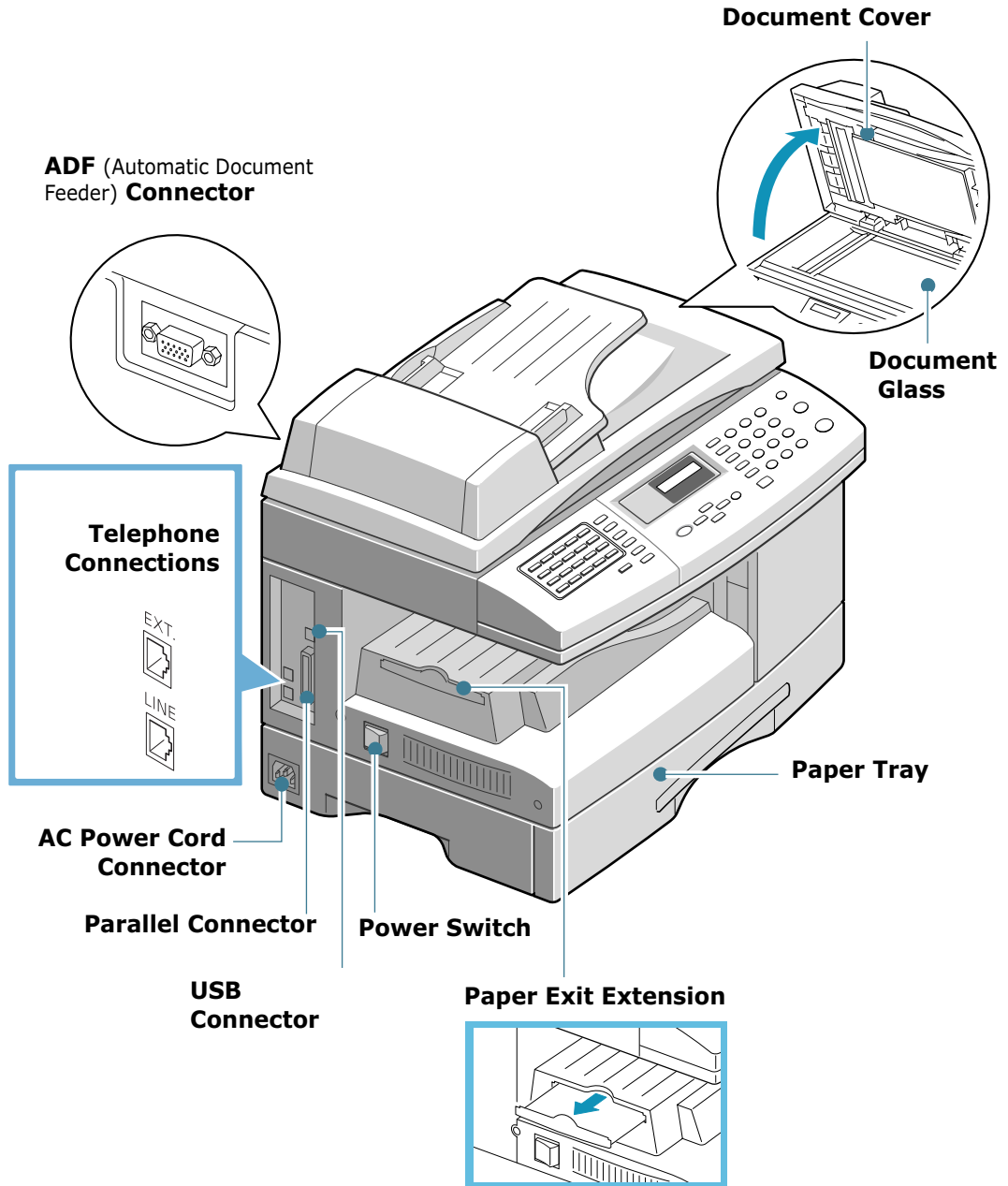



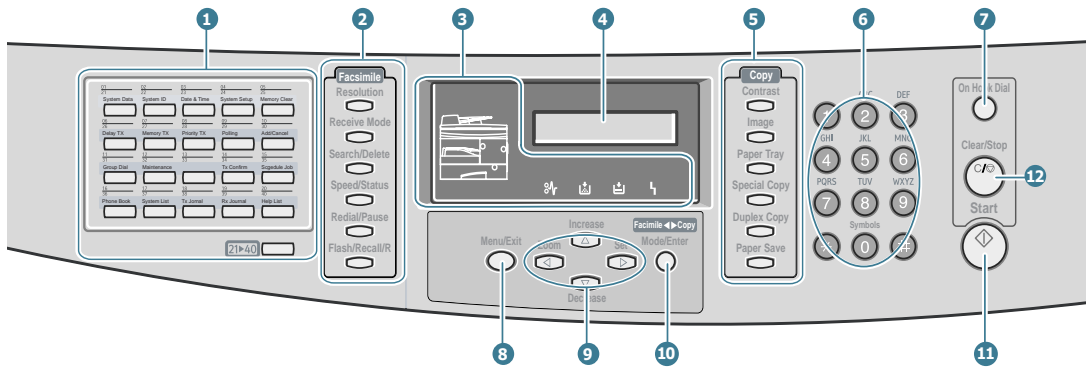



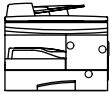
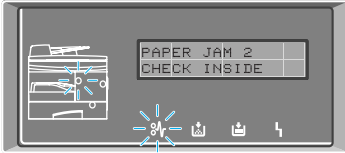
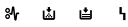

1











Control Panel Functions



1		Used to store frequently dialed fax numbers and dial them with the touch of one button. Also use in conjunction with the Menu/Exit button to access the corresponding menu function.
		Allows you to one-touch buttons to the locations 21 through 40.
2 <i>F</i> <i>a</i> <i>c</i> <i>s</i> <i>i</i> <i>m</i> <i>i</i> <i>e</i>		Adjusts the resolution of the current fax job documents.
		Used to choose the receive mode. The selected mode is displayed in Standby mode.
		Used to search for a number in the memory. Also used to delete digits in editing mode.
		Used to store frequently dialed fax numbers and dial them using the associated 2-digit speed dial number. Also used to alternately display alternately the currently active job and any pending jobs.
		Redials the last number in Standby mode or inserts a pause into a fax number in the edit mode.
		Used to perform a hook-switch operation, such as call waiting.

3	 <p>(status map)</p>	<p>When an error occurs, the lamp on the corresponding location on the Status map turns on, as well as the error indicator, and the error message appears on the display so that you can locate the error. For details on the meaning of the error messages, see page 8.11.</p>  <p>▲ ex) The paper is jammed in the exit area.</p>
	 <p>(Error indicators)</p>	 Turns on when a paper jam occurs. To clear the jam, see page 8.4.
		 Turns on when the toner or drum has almost run out. To replace the toner or drum cartridge, see page 7.3 and page 7.8.
		 Turns on when the input tray you are using is empty. To load paper, see page 1.15.
 Turns on when an error occurs on the system.		
4		Displays the current status and prompts during operation.
5 C o p y		Used to adjust the contrast of the current copy or fax job.
		Used to select the text type for the current copy job or fax job.
		Used to specify the paper tray you want to use in Fax or Copy mode.
		Used to set up special copy features, such as AutoFit, Clone, and Collation.
		The current copy job will use both sides of the paper when printed.
		Allows you to save paper by printing 2 pages on a single sheet of paper (available in the Copy mode only).

6		Used to dial a number or enter alphanumeric characters.
7		Engages the telephone line.
8		Enters the menu functions in conjunction with the one-touch buttons. Also backs you up to the previous menu level or exits the menu.
9*		Scrolls through the menu items. When you set the copy size or the copy page number, they can be used to change the number.
		Scrolls through the options available for the selected menu item. In the Copy mode, ◀ allows you to change the zoom rate and ▶ to change the number of copies.
10		Selects the mode to activate: FAX or COPY. Also, confirms the selection on the display.
11		Used to start a job.
12		Used to stop an operation at any time. Also, used to clear/cancel the copy options such as the zoom rate and multi copy pages in Copy mode.

* Navigation buttons

Making Connections

1

- 1 Connect the ADF (Automatic Document Feeder) cord to this port and fasten the side screws.

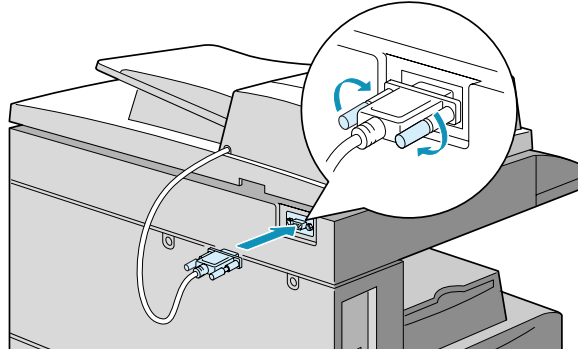

NOTE: Without connecting the cord to the port, you cannot use the ADF.

- 2 Connect the telephone line to the **LINE** jack and the other end to the wall jack.

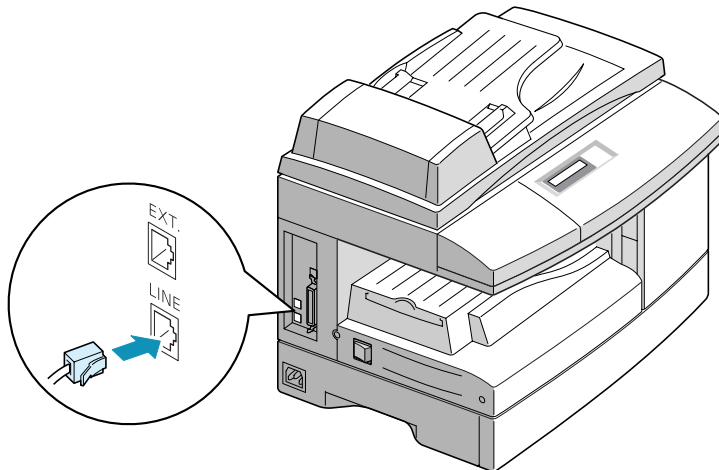

If you want to use your machine for receiving both faxes and voice calls, you will need to connect a telephone and/or answering machine to your machine.

Plug the cord of your extension phone or answering machine into the **EXT** jack.

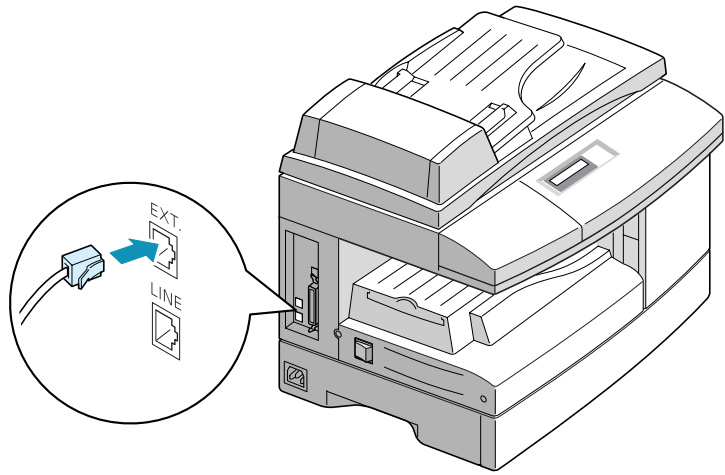

NOTE: You should use the telephone line cord which is supplied with your machine. If you are replacing it with another vendor's, it should be AWG #26 or lower gage.

3 Connect the USB cable which came with your machine.

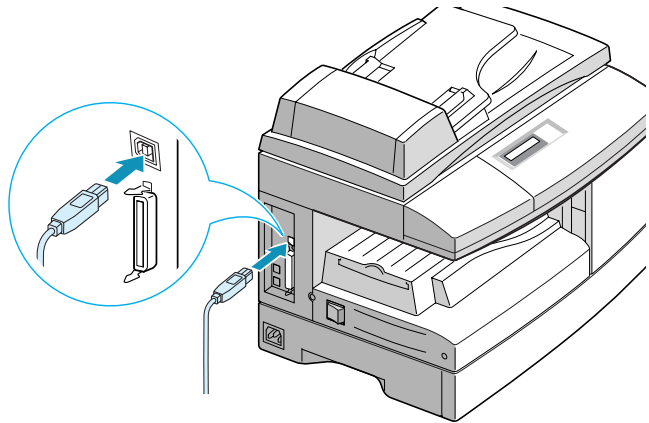

If you want to use a parallel printer cable, only use a IEEE 1284 compliant cable and connect it to the parallel connector on your machine.

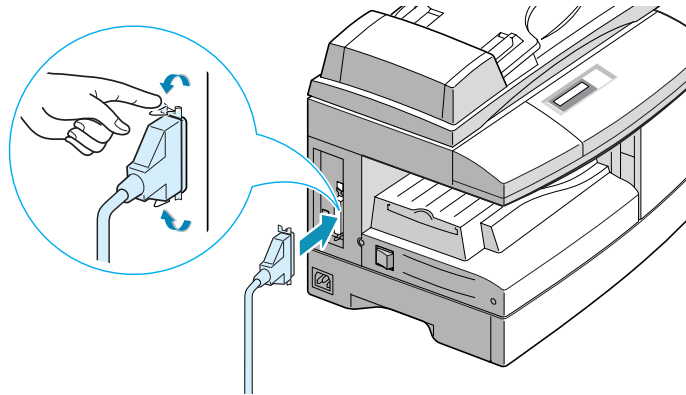

1



NOTE:

- To connect the machine to the parallel port of the computer requires a certified parallel cable. You will need to buy the a IEEE 1284 compliant cable.
- You only need to connect one of the above cables.
- If you are using a USB cable, you must be running Windows 98/Me/2000/XP.
- When using the a USB connection, your machine provides two USB modes; Fast and Slow. Fast is the default mode. Some PC user may experience poor USB function in the default mode. If this occurs, select the Slow mode to achieve successful results. For details on changing the USB mode, see page 8.16.

Installing the Drum and Toner Cartridges

- 1 Pull the release lever to open the side cover.

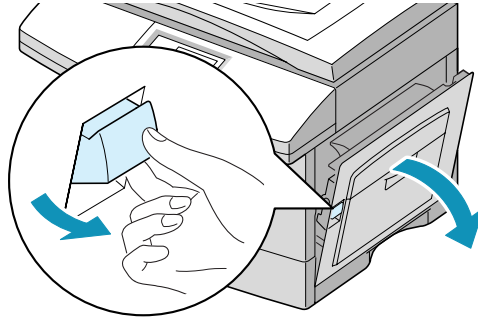

NOTE: Ensure that the side cover is always open before opening the front cover.

- 2 Open the front cover.

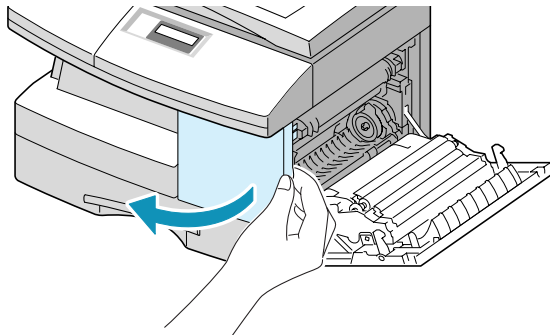

- 3 If the cartridge locking lever is on the lower position, turn the lever upward until it locks into place.

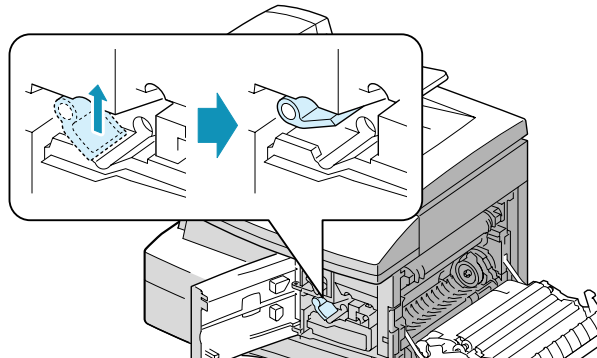

- 4 Remove the drum cartridge from its bag and slide it into the machine firmly until it locks into place completely.

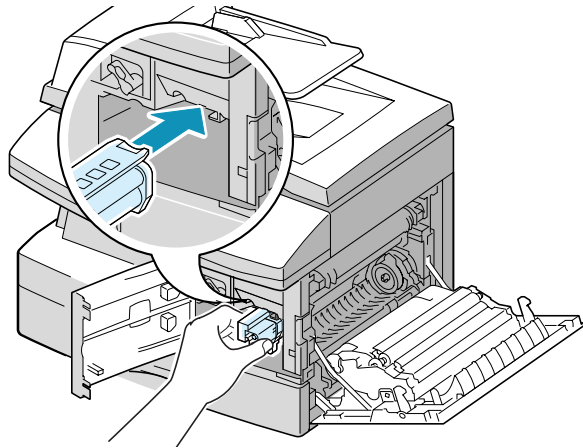

- 5 Remove the starter toner cartridge from its bag. Gently shake the cartridge to loosen the toner.

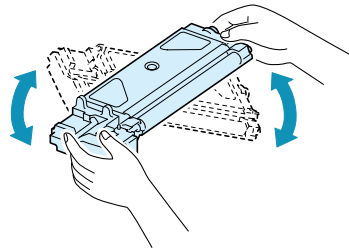

Thoroughly shaking the cartridge will assure maximum copies per cartridge.

- 6 Slide the toner cartridge into the machine aligning the cartridge to the left of the slot until it locks into place completely.

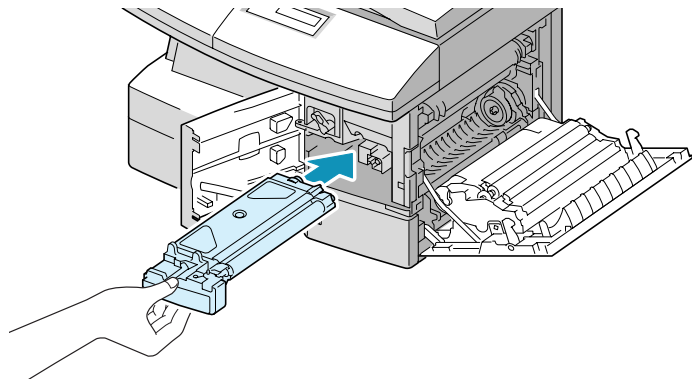

- 7 Turn the cartridge locking lever downwards until it locks into place.

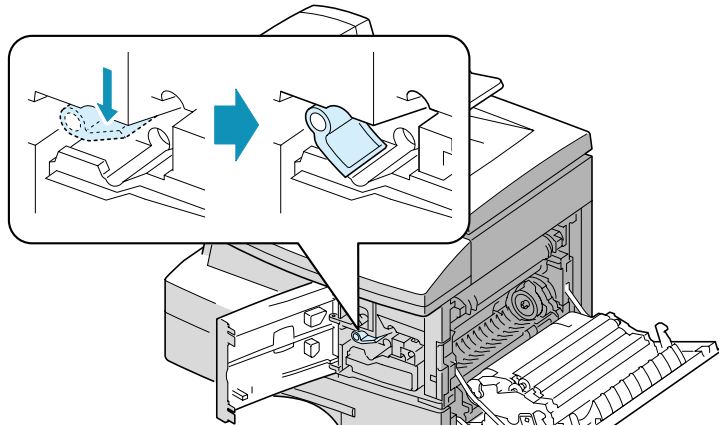

- 8 Close the front cover ❶ and then side cover ❷.

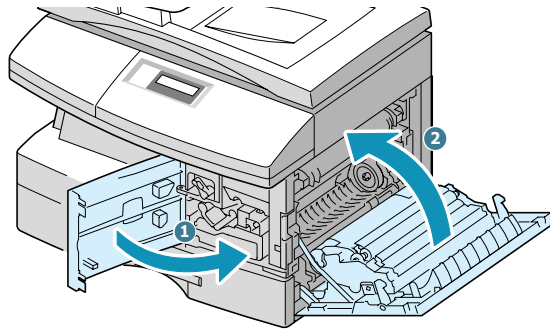

NOTE: When the drum or toner cartridge need to be replaced, the display indicates the corresponding message with the error indicator. Refer to the list of error messages on page 8.11.

To replace the drum and toner cartridges, see page 7.8 and page 7.3 respectively.

Turning the Machine On

- 1 Plug one end of the supplied three-wire electrical grounding type cord into the AC socket on the machine and the other end into a properly grounded AC outlet.

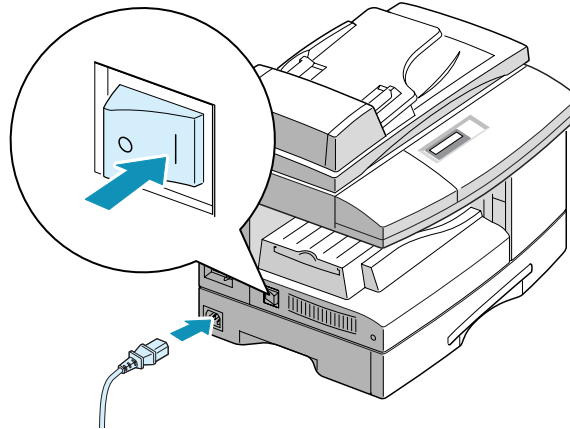

- 2 Turn on the power switch. "WARMING UP PLEASE WAIT" appears on the display indicating that the machine now is on.

To view your display text in another language, see page 1.19.



CAUTION: Power cord must be plugged into a grounded power socket.

Loading Paper

The paper Tray can hold a maximum of 550 sheets of 20lb plain paper. For copying or faxing, you can use A4-, letter-, or legal-size paper only.

- 1 Pull open the paper Tray.

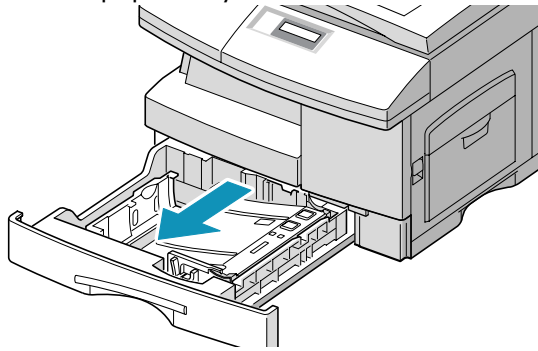

- 2 Push down on the pressure plate until it locks in position.

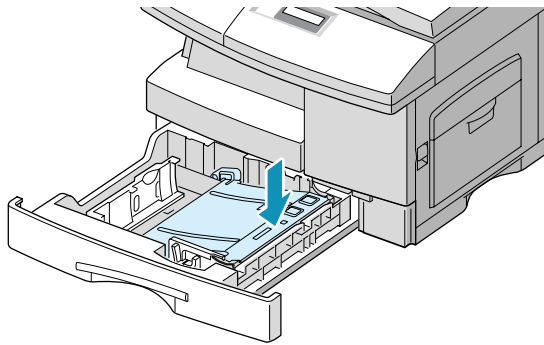

- 3 Adjust the rear paper guide to the desired paper length. It is preset to Letter or A4 size depending on the country. To load another size, lift and insert the rear guide into the corresponding position.

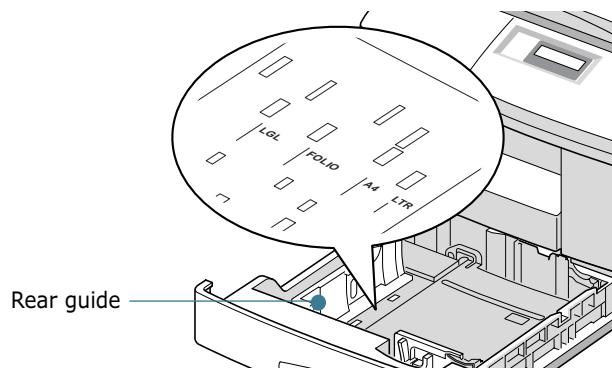

4 Fan the paper and insert it into the Tray.

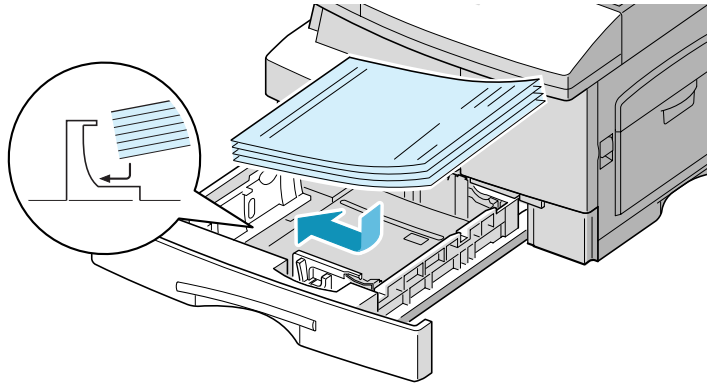

1

5 Ensure that the paper corners are under the corner snubbers.

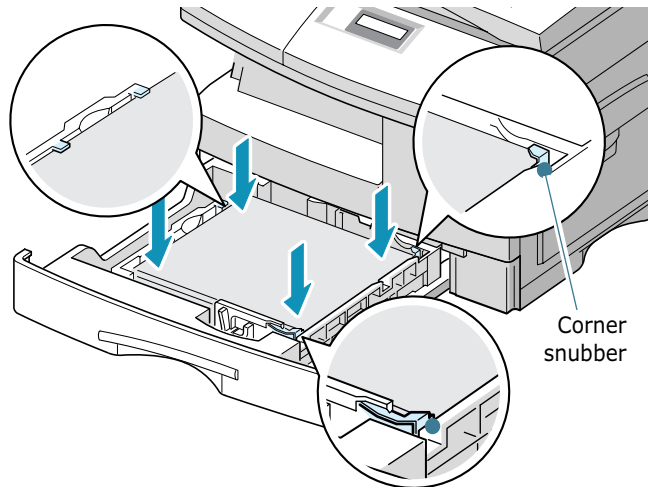

Do not fill above the max fill line.

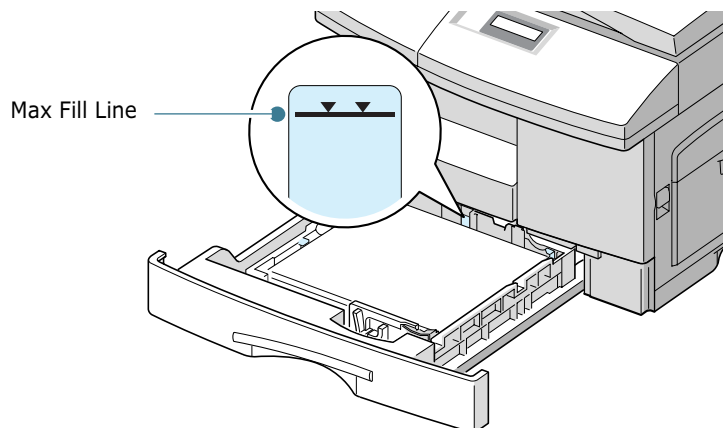

- 6 While pinching the side guide as shown, move it toward the stack of paper until it lightly touches the side of the stack. Do not press the guide too tightly to the edge of the paper; the guide may bend the paper.

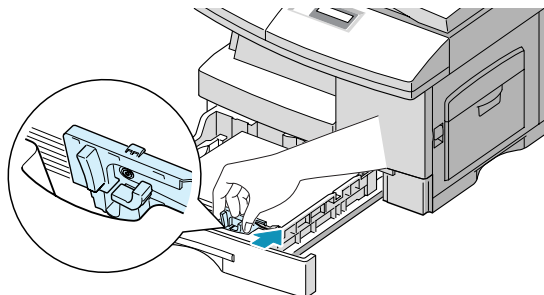

- 7 Close the paper Tray.

Tray Setting the Paper Size

After loading paper in the paper Tray, you need to set the paper size using the control panel buttons. These settings will apply to the Copy mode only. In the PC printing mode, you have to select the paper size in the application program you use.

- 1 Press **Menu/Exit** and then **System Data** from the one-touch dial keypad.

The display shows "CASSETTE PAPER" on the top line and the available options on the bottom line.

- 2 Use ◀ or ▶ to find the paper size you are using, and press **Mode/Enter** to save the selection.

You can press the corresponding number shown on the display to select the paper size.

- 3 To return to Standby mode, press **Clear/Stop**.

Changing the Display Language

To change the language that is displayed on the LCD display, take the following steps:

- 1 Press **Menu/Exit** and then **System Setup** from the one-touch dial keypad.
- 2 Press ▲ or ▼ until "SELECT LANGUAGE" appears on the top line of the display. The current setting appears on the bottom line of the display.
- 3 Press ◀ or ▶ until you see the language you want on the display.
- 4 Press **Mode/Enter** to save the selection.
- 5 To return to Standby mode, press **Clear/Stop**.

Using Save Modes

Paper Save

This feature prints 2 pages on a single sheet to save paper. To turn this feature on, take the following steps:

- 1 Press **Paper Save**. The display shows the current setting on the bottom line.
- 2 Press **Paper Save** or use the navigation buttons to change the setting. To enable the Paper Save mode, select "ON." Or select "OFF" to disable the mode.
- 3 Press **Mode/Enter** to save the selection.



NOTES:

- The Paper Save mode is available only when the document is loaded in the ADF.
 - The Paper Save mode is disabled when you set the collation or duplex copy options.
-

Power Save

The Power Save mode allows the printer to reduce power consumption when it is not in actual use.

You can select the length of time the machine waits after a job is printed before it switches to a reduced power state.

- 1 Press **Menu/Exit** and then **System Data** from the one-touch dial keypad.
- 2 Press \triangle or ∇ until "POWER SAVE" appears on the display. Make sure that "ON" blinks on the bottom line.

If necessary, use \triangleleft or \triangleright to select "ON" and press **Mode/Enter**.
- 3 The available time settings appear on the display and the current setting blinks. The available options are 5, 10, 15, 30, and 45 (minutes). Press \triangleleft or \triangleright until the desired time blinks.
- 4 Press **Mode/Enter** to save the selection.
- 5 To return to Standby mode, press **Clear/Stop**.



2

INSTALLING SOFTWARE

This chapter provides information about installing the supplied software.

The topics included in this chapter are:

- **About the Software**
- **System Requirements**
- **Installing the Software**
- **Removing Software**

About the Software

You must install software using the supplied CD-ROM after you have set up your machine and connected it to your computer.

The CD-ROM includes:

- Type 102 Software
- Operating Instructions
- Adobe Acrobat Reader

The CD-ROM provides you with the following software:

Type 102 Driver

To use your machine as a printer and scanner in Windows, you must install the Type 102 driver. For information about installing the Type 102 driver in Windows, see page 2.4.

Remote Control Panel

It is automatically installed when you install the Type 102 driver. For information about using the program, refer to the Facsimile Reference.

System Requirements

Before you begin, ensure that your system meets the minimum requirements.

Supported Operating System

- Windows 95 OSR2
- Windows 98/Windows 98 SE
- Windows Me
- Windows NT 4 Workstation or Server with Service Pack 3
- Windows 2000 Professional or Advanced Server
- Windows XP Home edition or Professional.

Minimal Requirements

- Disk space: 120 MB for installation
- Memory: 64 MB
- CPU: Pentium II 233 or higher
- Required software: Internet Explorer 5.0

Recommended

- Disk space: 220 MB for installation
- Memory: 128 MB
- CPU: Pentium II 400 or higher
- Required software: Internet Explorer 5.5



NOTES:

- For Windows NT 4.0/2000/XP, the system administrator should install the software.
 - Windows 95 versions prior to OSR2 are not recommended due to incompatibility with OLE/COM libraries.
-

Installing the Software



NOTES:

- Cancel the "New Hardware Found" window when your computer boots up.
- Make sure that your machine is plugged in and connected to your computer's parallel port or USB port **before installing software**. Windows 95 and Windows NT 4.0 do not support the USB connection.

- 1 Insert the supplied CD-ROM into your CD-ROM drive.

The CD-ROM should automatically run and an maintenance window appears.

If the maintenance window does not appear, click **Start** and then **Run**. Type **X:\Setup.exe**, replacing "X" with the letter of your drive and click **OK**.



NOTE: If your machine is not connected to the computer, the following window will appear.

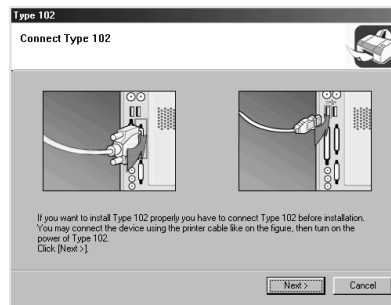

- After connecting the machine, click **Next**.
- If you want to skip the connection status, click Next, and No to the following screen. Then the installation will start and the test page will not be printed at the end of the installation.
- For details about installation problems, see p.2.6 "Removing Software", Copy/Printer/Scanner Reference." when you have some problems during installation.

2 Choose the installation type.

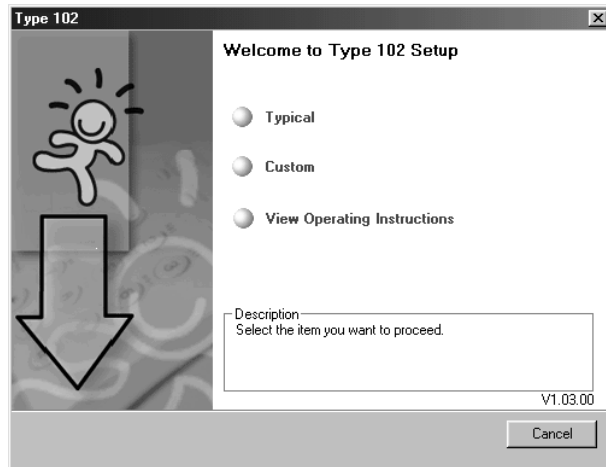

- **Typical:** Installs the common software for your printer, such as Printer driver, Twain driver, Remote Control Panel. This is recommended for most users.
- **Custom:** Allows you to choose the language of the software and the components you want to install. After selecting the language and the component(s), click **Next**.

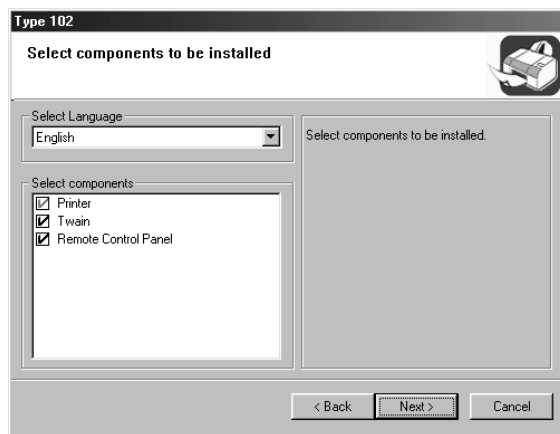

- **View Operating Instructions:** Allows you to view this Operating Instructions. If your computer doesn't have Adobe Acrobat, click on this option and it will automatically install Adobe Acrobat for you.

- 3 After the installation is finished, the window asking you to print a test page appears. If you choose to print a test page, select the check box and click **Next**.
- 4 When the test page prints out correctly, click **Yes**.
If not, click **No** to reprint it.
- 5 Click **Finish**.

Removing Software

Uninstall is required if you are upgrading the software or if your installation fails. You can uninstall all software of this machine, using the CD-ROM or uninstall the desired item using the Windows unInstallShield.

- 1 You can select **Start** → **Programs** → **Type 102** → **Maintenance**.

Otherwise, insert the supplied CD-ROM into your CD-ROM drive.

The CD-ROM should automatically run and an installation window appears.

If the Maintenance window does not appear, click **Start** and then **Run**. Type **X:\Setup.exe**, replacing "X" with the letter of your drive and click **OK**.

- 2 Click **Remove**.

Then you will see a component list so that you can remove any of them individually.

If you want to uninstall the Printer driver, check **Printer**.

If you want to uninstall the Twain driver, check **Twain**.

If you want to uninstall the Remote Control Panel, check **Remote Control Panel**.

- 3 After selecting items you wish to remove, click **Next**.

- 4 When your computer asks you to confirm your selection, click **Yes**.

The selected driver and all of its components are removed from your computer.

- 5 When the uninstallation is done, click **Finish**.



3

PAPER HANDLING

This chapter introduces you to the basics of selecting print media and loading print media into your machine.

This chapter includes:

- **Selecting Print Media**
- **Paper Guidelines**
- **TrayLoading Paper in the Tray**
- **Using the Bypass Tray**
- **Setting the Paper Size for Copying**

Selecting Print Media

Always use print media that meets the guidelines for use with this machine. Using a print media that is not recommended may cause paper jams or print quality problems.

Media Size Input Sources and Capacities

Media Size	Input Source/Capacity ^a	
	Paper Tray	Bypass Tray
Plain paper		
Letter (8.5 x 11 in.)	YES/550	YES/100
Folio (8.5 x 13 in.)	YES/550	YES/100
Legal (8.5 x 14 in.)	YES/550	YES/100
Executive (7.25 x 10.5 in.)	NO/0	YES/100
A4 (210 x 297 mm)	YES/550	YES/100
B5 (182 x 257 mm)	NO/0	YES/100
A5 (148 x 210 mm)	NO/0	YES/100
Envelopes		
No. 10 (4.12 x 9.5 in.)	NO/0	YES/10
C5 (162 x 229 mm)	NO/0	YES/10
DL (110 x 220 mm)	NO/0	YES/10
Monarch (3.87 x 7.5 in.)	NO/0	YES/10
B5 (176 x 250 mm)	NO/0	YES/10
Labels^b		
Letter (8.5 x 11 in.)	NO/0	YES/30
A4 (210 x 297 mm)	NO/0	YES/30
Transparency films^b		
Letter (8.5 x 11 in.)	NO/0	YES/30
A4 (210 x 297 mm)	NO/0	YES/30
Card stocks^b		
A6 (105 x 148 mm)	NO/0	YES/10
Post Card (4 x 6 in.)	NO/0	YES/10
Hagaki (100 x 148 mm)	NO/0	YES/10

- Maximum capacity may be reduced depending on paper thickness.
- If you are experiencing excessive jamming, feed one sheet at a time through the Bypass Tray.

Paper Guidelines

When selecting or loading paper, envelopes, or other special media, keep these guidelines in mind:

- Attempting to print on damp, curled, wrinkled, or torn paper can cause paper jams and poor print quality.
- Use only high quality copier grade paper. Avoid paper with embossed lettering, perforations, or texture that is too smooth or too rough.
- Store paper in its ream wrapper until ready to use. Place cartons on pallets or shelves, not on the floor. Do not place heavy objects on top of the paper, whether it is packaged or unpackaged. Keep it away from moisture, or other conditions that can cause it to wrinkle or curl.
- During storage, moisture-proof wrap (any plastic container or bag) should be used to prevent dust and moisture from contaminating your paper.
- Always use paper and other media that conform with the specifications listed under "General Specifications" on page A.2.
- Use only well-constructed envelopes with sharp, well creased folds.
 - DO NOT use envelopes with clasps and snaps.
 - DO NOT use envelopes with windows, coated lining, self-adhesive seals, or other synthetic materials.
 - DO NOT use damaged or poorly made envelopes.
- It is recommended that you feed special paper types one sheet at a time.
- Only use the special media recommended for use in laser printers.
- To prevent special media such as transparencies and label sheets from sticking together, remove them from the exit tray as they are printed.
- Place transparencies on a flat surface after removing them from the machine.
- Do not leave the film in the paper tray for long periods of time. Dust and dirt may accumulate on them resulting in spotty printing.
- To avoid smudging caused by fingerprints, handle transparencies and coated paper carefully.
- To avoid fading, do not expose the printed transparencies to prolonged sunlight.

- Store unused media at temperatures between 59°F and 86°F (15°C to 30°C). The relative humidity should be between 10% and 70%.
- Do not load more than 10 sheets of special media into the Bypass Tray at a time.
- Verify that your labels' adhesive material can tolerate fusing temperature of 200°C (392°F) for 0.1 second.
- Make sure that there is no exposed adhesive material between labels. Exposed areas can cause labels to peel off during printing, which can cause paper jams. Exposed adhesive can also cause damage to machine components.
- Do not feed a sheet of labels through the machine more than once. The adhesive backing is designed for one pass through the machine.
- Do not use labels that are separating from the backing sheet or are wrinkled, bubbled, or otherwise damaged.

TrayLoading Paper in the Tray

The paper Tray can hold a maximum of 550 sheets of 20lb(75g) plain paper. For copying or faxing, you can use A4-, letter-, or legal-size paper only.

To load paper, pull open the paper Tray and place paper with the side you want to print facing up.

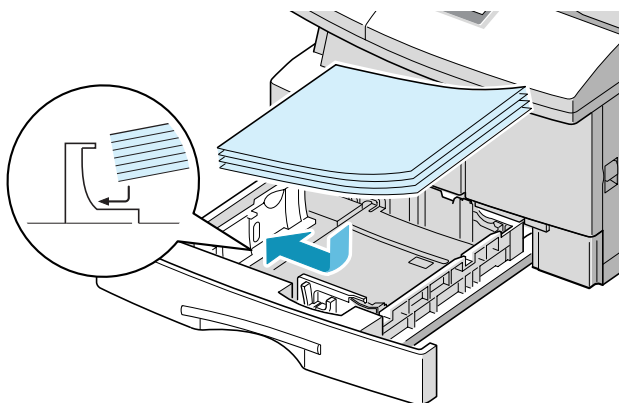

You can load letterhead paper with the design side facing up. The top edge of the sheet with the logo should be placed at the right side.

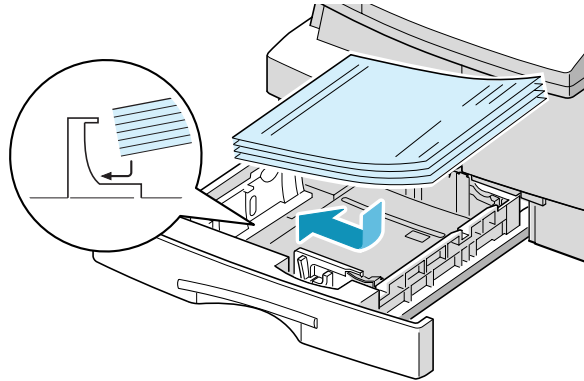

For details on loading paper in the Tray, see page 1.15.

After loading paper in the Tray, you need to set the correct paper size using the control panel buttons. See page 1.19.



NOTES:

- When you print a file from your PC using the paper Tray, make sure that you select the Paper source and the correct paper size from your software application before starting your print job.
- If you experience problem with the paper feed, place the paper in the Bypass Tray.
- You can load up to 300 sheets of previously printed paper. The printed side should be facing down with the uncurled edge at the right side. If you experience problems with the paper feed, turn the paper around. Note that the print quality is not guaranteed.

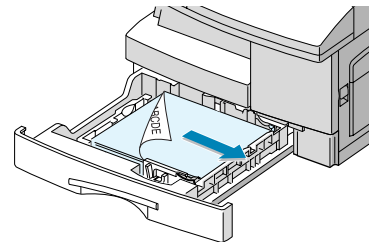

Using the Bypass Tray

Bypass Tray is located at the right side of your machine. It can be closed when you are not using it, making the machine more compact.

Use the Bypass Tray to print transparencies, labels, envelopes or postcards in addition to making quick runs of paper types or sizes that are not currently loaded in the paper Tray.

Acceptable print media are plain paper with sizes ranging from 98 x 148 mm (3.9 x 5.8 in.) to Legal 216 x 356 mm (8.5 x 14 in.), the largest size acceptable, and weighing between 16lb and 32lb.

The following table summarizes the print media allowed as well as their stacking height limit.

Paper Type	Stacking Height Limit
Plain Paper	100 sheets or 9mm (max) ^a
Envelope	10 envelopes or 9mm (max) ^a
Transparency	30 sheets or 9mm (max) ^a
Label	30 sheets or 9mm (max) ^a
Cardstock	10 sheets or 9mm (max) ^a

a. The height is measured with the stack of sheets untouched laid on a flat surface.



Notes:

- Always load only use print media specified in Specifications to avoid paper jams and print quality problems.
 - Do not hit the Bypass Tray or rest your hands on it; otherwise the tray may be damaged or detached from the machine.
 - Flatten any curling on postcards, envelopes, and labels before loading them into the Bypass Tray.
-

To load print media in the Bypass Tray:

- 1 Lower the Bypass Tray, located on the right side of the machine. Unfold the paper support extension as shown.

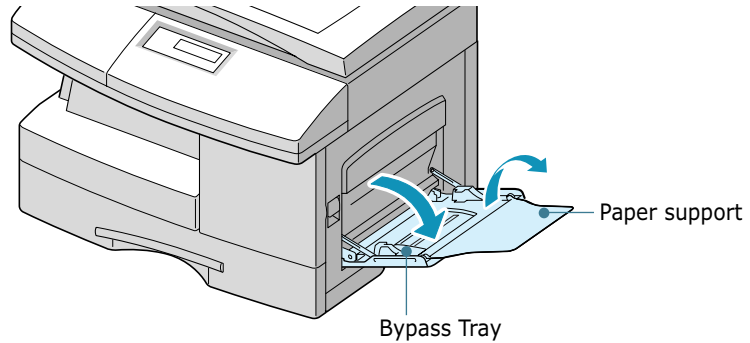

3

- 2 Prepare a stack of paper or envelopes for loading by flexing or fanning them back and forth. Straighten the edges on a level surface.

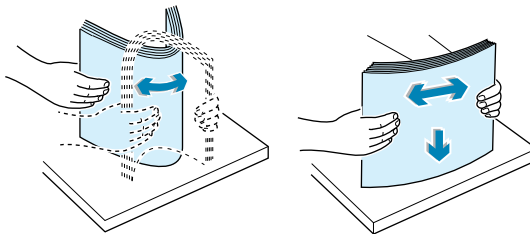

For transparencies, hold the transparencies by the edges and avoid touching the print side. Oils from your fingers that are deposited on the transparency can cause print quality problems. If you are using the transparencies with paper backing, insert a sheet of plain paper on the tray before loading transparencies. Doing so prevents paper jams while feeding.

- 3 Load the print material with the side you want to print facing down and against the right edge of the tray.

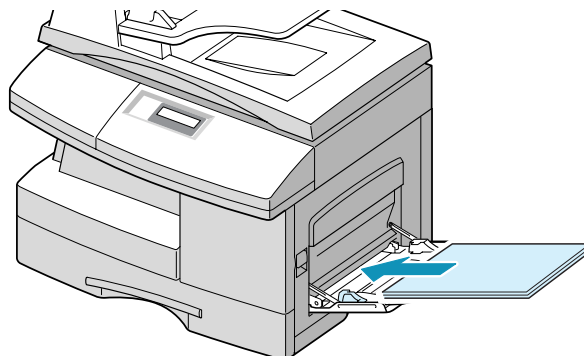

- 4 Adjust the paper guide to the width of the stack of print material.

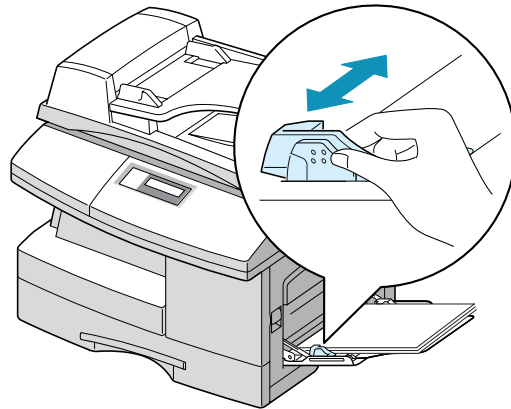

Make sure that you have not loaded too much print media. The stack should be under the Max. fill line. The print media buckles if you load a stack that is too deep or if you push it in too far.

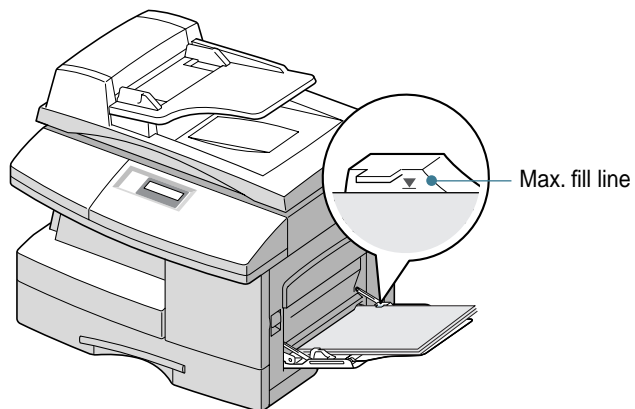

NOTES: When printing on previously used paper via the Bypass Tray, the printed side should be facing up with the uncurled edge at the left side. If you experience problems with paper feed, turn the papers around.

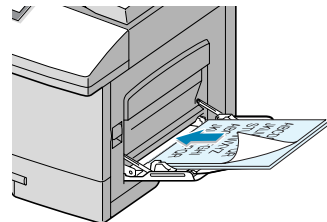

Setting the Paper Size for Copying

After loading paper in the paper Tray or the Bypass Tray, you need to set the correct paper size using the control panel buttons. These settings will apply to the Copy mode, and the Fax mode. In PC printing mode, you have to select the paper size in the application program you use.

To set the paper size for Tray, take the following steps:

- 1 Press **Menu/Exit** and then **System Data** from the one-touch dial keypad.

The display shows "CASSETTE PAPER" on the top line and the available options on the bottom line. The current setting blinks.

- 2 Use ◀ or ▶ to select the paper size you are using, and press **Mode/Enter** to save the selection.

You can press the corresponding number shown on the display to select the paper size.

- 3 To return to Standby mode, press **Clear/Stop**.

To set the paper size for the Bypass Tray, take the following steps:

- 1 Press **Menu/Exit** and then **System Data** from the one-touch dial keypad.

The display shows "CASSETTE PAPER" on the top line and the available options on the bottom line.

- 2 Use ▼ to display "BYPASS PAPER" on the top line. The available options appear on the bottom line and the current setting blinks.

- 3 Use ◀ or ▶ to select the paper size you are using, and press **Mode/Enter** to save it.

You can press the corresponding number shown on the display to select the paper size.

- 4 To return to Standby mode, press **Clear/Stop**.

NOTE



4

COPYING

This chapter provides step-by-step instructions for copying documents.

This chapter includes:

- **Loading Paper for Copy Output**
- **Selecting a Paper Tray**
- **Making Copies from the Automatic Document Feeder**
- **Making Copies using the Document Glass**
- **Setting Copy Options**
- **Auto Fit Copying**
- **Clone Copying**
- **Duplex Copying**
- **Collation Copying**

Loading Paper for Copy Output

You can copy to a size of media as small as an index card 98 x 148 mm (3.9 x 5.8 in.) or as large as a sheet of legal-sized 216 x 356 mm (8.5 x 14 in.) paper.

The instructions for loading the print media are the same whether you are printing, faxing, or copying. For details, see page 1.15 and page 3.6.

Selecting a Paper Tray

After loading the print media for use when copying, you have to select the paper tray you will use for both copy and fax jobs.

- 1** Press **Paper Tray**. The current setting appears on the bottom line of the display.
- 2** Select "CASSETTE" or "BYPASS" by pressing **Paper Tray** repeatedly or using the navigation buttons, and press **Mode/Enter** to save the selection.
- 3** If you selected "BYPASS" at the step 2, the display prompts you to select the PAPER TYPE for the Bypass Tray.

Use the navigation buttons to select the paper type you are using in the Bypass Tray.
- 4** Press **Mode/Enter** to save the selection.

Making Copies from the Automatic Document Feeder

Using the ADF (Automatic Document Feeder), you can load up to 30 documents (20lb, 75 g/m²) in one job. Ensure that documents are in good condition, that they have the same thickness and weight, and that all of the staples and paper clips have been removed.

- 1 Feed the documents (up to 30 pages) **face up** into the ADF and adjust the document guides to the document size. Make sure that the bottom of the document stack matches the paper size marked on the ADF.

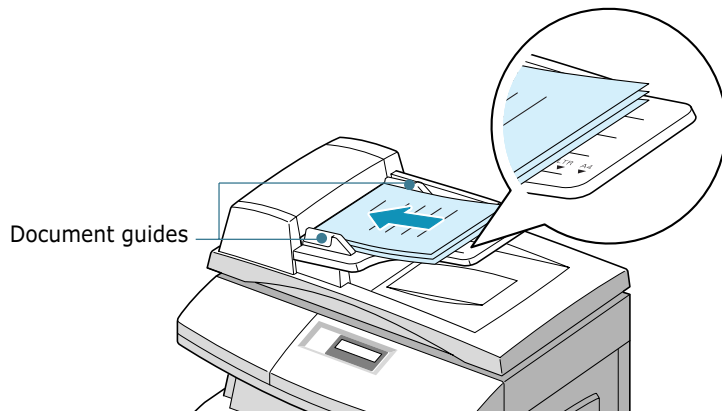

4

- 2 Users should verify that the machine is in the Copy mode. If necessary, press **Mode/Enter** to change the mode to Copy mode. In Copy mode, the LCD display shows:



Note that you cannot make copies in Fax mode. The machine will sound an error beep.

- 3 Make sure that you have selected the required paper tray. See page 4.2.
- 4 Customise the copy settings including the number of copies, copy size, contrast and image type using the control panel buttons. See "Setting Copy Options" on page 4.6.

To clear the settings, use the **Clear/Stop** button.

- 5 If necessary, you can use special copy features, such as collation and duplex copying.

- 6 Press **Start** to begin copying. The display shows the copy processing.



NOTE: Dust on the ADF glass may cause black lines on the printout, so always keep it clean.

Making Copies using the Document Glass

If you want to make copies from booklet, pamphlet, transparencies, or documents having other unusual characteristics, use the document glass to load documents.

- 1 Lift the document cover.

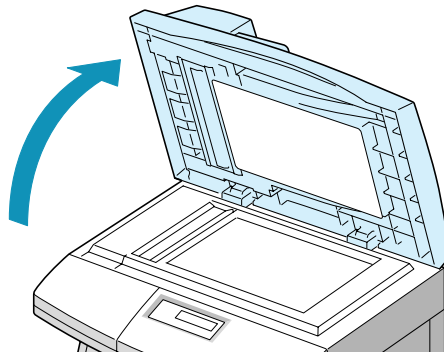

- 2 Place the document **face down** on the glass and align it with document guides on the left top corner of the document glass.

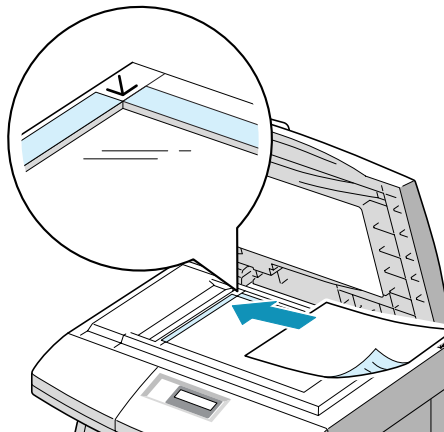



NOTE: Make sure that no other documents are in the ADF. If a document is detected in the ADF, this document has the priority rather than the document on the scan glass.

3 Close the scanner cover.



NOTES:

- Leaving the cover open while copying will affect the copy quality and toner consumption.
- If you are copying a page from a book or magazine, close the cover flat. The slanted cover may cause heavy exposure of the light when scanning.

4 Users should verify that the machine is in the Copy mode. If necessary, press **Mode/Enter** to change the mode to Copy mode. In Copy mode, the LCD display shows:



Note that you cannot make copies in Fax mode. The machine will sound an error beep.

5 Make sure that you have selected the required paper tray. See page 4.2.

6 Customise the copy settings including the number of copies, copy size, contrast and image type using the control panel buttons. See "Setting Copy Options" on page 4.6.

To clear the settings, use the **Clear/Stop** button.

7 If necessary, you can use special copy features, such as Auto Fit and Clone.

8 Press **Start** to begin copying. The display shows the copy processing.



NOTES:

- You can cancel a copy job while it is copying by Press the **Clear/Stop** button.
- Dust on the document scanner glass may cause black spots on the printout, so always keep it clean.

Setting Copy Options

The following buttons on the control panel let you set all the basic copy options; contrast, image type, number of copies and copy size. When making a copy, use these buttons before pressing **Start**.

Image

The Image setting is used to improve the copy quality. To select the image type, take the following steps:

- 1** Press **Image**. You can see the current setting on the bottom line of the display.
- 2** Press **Image** or the navigation buttons until the desired mode appears. You can choose from:
 - TEXT:** Used for documents containing mostly text.
 - MIXED:** Used for documents with mixed text and graphics.
 - PHOTO:** Used when the originals are photographs.
- 3** Press **Mode/Enter** to save the selection.

Contrast

If you have an original document containing faint markings or dark images, you can adjust the brightness to make a copy that is easier to read. To adjust the contrast, take the following steps:

- 1 Press **Contrast**.
- 2 Press **Contrast** or the navigation buttons to select an option and press **Mode/Enter**.
MANUAL: You can adjust the contrast manually. Continue to the next step.
AUTO SUPPRESS: Use this setting for copying an original from a newspaper or magazine to remove its background image. This setting is available only in the Copy mode.
- 3 When you select **Manual**, choose from 5 contrast settings using the navigation buttons.

Each time you press the button, the selection block on the LCD display moves to the left or to the right. As the selection block moves to the right, the contrast becomes darker.



- 4 Press **Mode/Enter** to save the selection.

Set

Using the **Set** (▷) button, you can select the number of copies, from 1 to 999.

- 1 Press **Set** (▷). The triangle symbol on the middle of the top line heads for the number of copies.
- 2 Enter the number of copies using the number keypad. The selected number appears on the display.

You can also use **Increase** (△) or **Decrease** (▽) to change the number of copies. Press **Increase** (△) or **Decrease** (▽) to increase or decrease the number by 1. If you press and hold the buttons, the number increases or decreases rapidly.

- 3 Press **Mode/Enter** to save the selection.

Zoom

Using the **Zoom** (◀) button, you can reduce or enlarge the size of a copied image by 25% to 400% when you copy the original from the document scanner glass, and by 25% to 100% using the ADF. Note that the zoom rate available is different according to the document loading method.

- 1 Press **Zoom** (◀). The triangle symbol on the middle of the top line points to the zoom rate.
- 2 Enter the size using the number keypad. The selected number appears on the display.

You can also use **Increase** (△) or **Decrease** (▽) to change the zoom rate. Press **Increase** (△) or **Decrease** (▽) to increase or decrease the number by 1. If you press and hold the buttons, the number increases or decreases rapidly.

- 3 Press **Mode/Enter** to save the selection.



NOTES:

- If you press the **Clear/Stop** button while setting the copy options and before starting to copy, all the copy options you have set for the current copy job will be cancelled and return to their default values.
 - When reducing, black lines may appear at the bottom of the copy.
-

Auto Fit Copying

This feature automatically reduces or enlarges the original image to fit on the paper currently loaded in the machine, so you don't need to adjust the copy size.

This special copy mode is only available when using document scanner glass. If a document is detected in the ADF, the auto-fit will not work.

- 1 Load the document to be copied on the document glass, and close the cover.
- 2 Make sure that you have selected the required paper tray. See page 4.2.
- 3 To enter the special copy mode, Users should press **Special Copy** in the Copy mode (see page 4.5).
- 4 Press **Special Copy** repeatedly or use the navigation buttons until "AUTO FIT" appears on the bottom line of the display.
- 5 Press **Mode/Enter** to save the selection.
- 6 If necessary, customise the copy settings including the number of copies, contrast and image type using the control panel buttons. See "Setting Copy Options" on page 4.6.



NOTE: You cannot adjust the copy size using the **Zoom** button while Auto fit is enabled.

- 7 Press **Start** to begin copying.
- 8 When copying is completed, press **Clear/Stop** to cancel the Auto Fit mode.

Clone Copying

The Clone feature prints multiple image copies on a single page. The number of images is automatically determined by the original image size, so you are unable to adjust the copy size.

This special copy mode is available only when using the document scanner glass. If a document is detected on the ADF, the Clone option will not work.

- 1 Load the document to be copied on the document glass, and close the cover.
- 2 Make sure that you have selected the required paper tray. See page 4.2.
- 3 To enter the special copy mode, Users should press **Special Copy** in the Copy mode (see page 4.5).
- 4 Press **Special Copy** repeatedly or use the navigation buttons until "CLONE" appears on the bottom line of the display.
- 5 Press **Mode/Enter** to save the selection.
- 6 If necessary, customise the copy settings including the number of copies, contrast and image type using the control panel buttons. See "Setting Copy Options" on page 4.6.



NOTE: You cannot adjust the copy size using the **Zoom** button while making a clone.

- 7 Press **Start** to begin copying.
- 8 When the copying is completed, press **Clear/Stop** to cancel the Clone mode.

Duplex Copying

Duplex copying allows you to print on both sides of the paper.

Before printing in the duplex mode, decide on which edge you will bind your finished document. The binding options are:

LONG EDGE, which is the conventional layout used in book binding.

SHORT EDGE, which is the type often used with calendars.

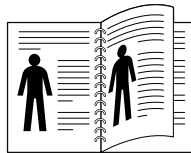

▲ Long Edge

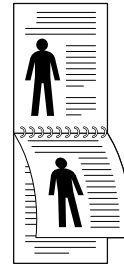

Short Edge ►

- 1 Load the documents to be copied in the ADF. Make sure that the original document is single sided.

Or, place a sheet of the documents on the document glass face down.
- 2 Make sure that you have selected the required paper tray. See page 4.2.
- 3 Press **Duplex Copy**. The current setting appears on the bottom line of the display.
- 4 Press **Duplex Copy** or use the navigation buttons to select the binding orientation. If you select "OFF", you cannot use duplex copying.
- 5 Press **Mode/Enter** to save the selection.
- 6 If necessary, customise the copy settings including the number of copies, copy size, contrast and image type using the control panel buttons. See "Setting Copy Options" on page 4.6.



NOTE: In duplex copy mode, the PHOTO setting using the **Image** button is disabled.

- 7 Press **Start** to begin copying.

- 8 When the document is fed from the document glass, the display shows "SCAN SIDE 2?" on the top line after the page is scanned into the memory. To scan another page, remove the scanned page and load the next page on the glass. Select "YES" and press **Mode/Enter**.

After scanning, the machine starts printing automatically. Then the display shows "SCAN ANOTHER?". To scan another page, select "YES" and press **Mode/Enter**.

When the display shows "SCAN SIDE2?" again, repeat as necessary.

When all of the pages are scanned, select "NO" when the display shows "SCAN SIDE 2?" or "SCAN ANOTHER ?" and press **Mode/Enter**.

- 9 When the copying is completed, press **Clear/Stop** to cancel the duplex copy mode.

Collation Copying

When the Collation Copying feature is on, your machine sorts the copy job. For example, if you make 2 copies of 3 pages documents, one complete 3 page document will print followed by the second complete 3 page document.

- 1 Load the documents to be copied in the ADF.

Or, place a sheet of the documents on the document glass face down.
- 2 Make sure that you have selected the required paper tray. See page 4.2.
- 3 To enter collation copy mode, Users should press **Special Copy** in the Copy mode (see page 4.3). Press **Special Copy** or use the navigation buttons until "COLLATION" appears on the bottom line of the display.
- 4 Press **Mode/Enter** to save the selection.

- 5 If necessary, customise the copy settings including the number of copies, copy size, contrast and image type using the control panel buttons. See "Setting Copy Options" on page 4.6.
- 6 Press **Start** to begin copying.



NOTE: In duplex copy mode, the PHOTO setting using the **Image** button is disabled.

- 7 When the document is fed from the document glass, the display shows "SCAN ANOTHER?" on the top line after the page is scanned into the memory. To scan another page, remove the scanned page and load the next page on the glass. Select "YES" and press **Mode/Enter**. Repeat as necessary.

When all of the pages are scanned, select "NO" when the display shows "SCAN ANOTHER?" and press **Mode/Enter**.

- 8 When copying is completed, press **Clear/Stop** to cancel the collation copy mode.

MEMO



5

PRINTING

Read this chapter to learn how to select and load print media and how to use the print settings.

This topics included in this chapter are:

- **Printing a Document**
- **Printer Settings**
- **Printing Multiple Pages on One Sheet of Paper (N-Up Printing)**
- **Printing a Reduced or Enlarged Document**
- **Fitting Your Document to a Selected Paper Size**
- **Printing Posters**
- **Using Watermarks**
- **Using Overlays**
- **Setting Graphic Properties**
- **Setting Up the Locally Shared Printer**

Printing a Document

This procedure describes the general steps required for printing from various Windows applications. The exact steps for printing a document may vary depending on the application program you are using. Refer to your software application's for the exact printing procedure.

The following steps describe the typical process to print from Windows:

- 1 Ensure that your machine is properly connected to the computer, the machine is powered on, and there is paper in the paper tray.
- 2 Verify that you have installed the software for your computer. For details, see "Installing the Software" on page 2.4.
- 3 Start the program you are using to create the document, and create or open the document you want to print.
- 4 Choose **Print** or **Print Setup** from the **File** menu. Make sure that **Type 102 PCL 6** is selected as your default printer. Click **Properties** or **Setup** if you want to make any adjustments that are appropriate for printing your document. For details, see "Printer Settings" on page 5.3.

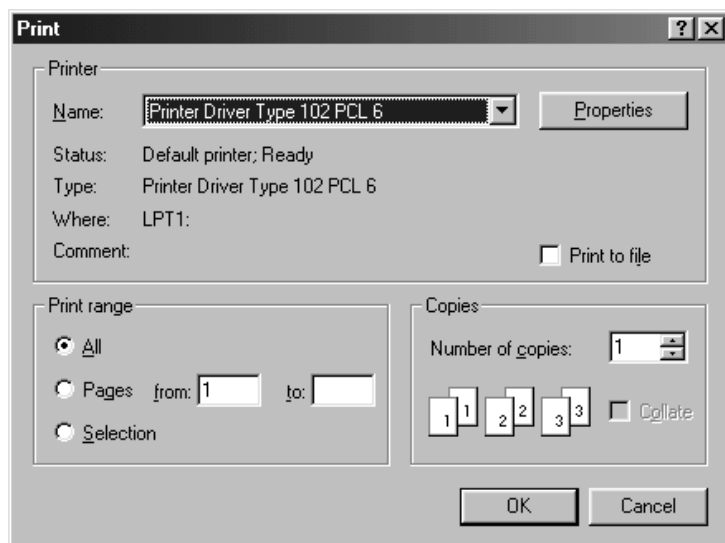

- 5 Click **OK** to close the Properties dialogue box.

- 6 After making any necessary changes to the printing parameters, click **OK** to start the print job.

Printer Settings

You can use the machine with all your Windows 95/98/Me/2000/XP or Windows NT 4.0 applications. Be sure to set Type 102 PCL 6 as the default printer for all of your Windows operations.

Most Windows software applications allow you to make changes to the printer settings. This includes settings that determine how a print job looks such as paper size, paper orientation, and margins. Settings made in the application to create the document will usually override settings made in the printer driver.



NOTE: You do not need to use any of the control panel buttons to use the machine as a PC printer. For example, if you want to adjust the printing contrast you do not have to press **Contrast** on the control panel. The control panel buttons are used primarily for copying.

Accessing Printer Settings

You can access printer settings by using either of these methods.

Windows 95/98/Me

- Select the **File > Print > Properties** or **File > Print Setup** command from within any Windows application.

Or

- Select **Type 102 PCL 6** printer from the **Printers** folder, then select **File > Properties** (or select the printer icon in the **Printers** folder, and click the right mouse button).

Windows NT 4.0

- Select the **File > Print > Properties** or **File > Print Setup** command from within any Windows application.

Or

- Select **Type 102 PCL 6** printer from the **Printers** folder, click the right mouse button, then select **Document Defaults** from the drop-down list.

Windows 2000

- Select the **File > Print** command from within any Windows application.
Or
- Select **Type 102 PCL 6** printer from the **Printers** folder, click the right mouse button, then select **Properties** and **Printing Preferences** from the drop-down list.

Windows XP

- Select the **File > Print > Preferences** command from within any Windows application.
- Select **Type 102 PCL 6** printer from the **Printers and Faxes** folder, click the right mouse button, then select **Printing Preferences** from the drop-down list.

Printer Properties Tabs

When Printer Properties are displayed, you can review and change whatever settings are needed for your printer job.

Your printer's Properties window consists of 5 tabs: **Layout**, **Paper**, **Graphic**, **Extras** and **About**.

If you access the Printer Properties through the **Printers** folder, you can view more Windows-based tabs, in addition to these 5 tabs. For information on the Windows-based tabs, refer to your Windows User's Guide.

The printer's Properties window may differ depending on the operating system used. This Operating Instructions shows the Properties window on Windows unless otherwise specified.



NOTE: If you access Printer Properties through the **Printers** folder, any settings made will become the default settings for the printer. Settings made when Printer Properties are accessed through an application **File** menu and **Print** or **Print Setup** will remain active until the application you are printing from is closed.

Paper Tab

Use the **Paper** tab to select the size of paper you have in your printer, the orientation, the number of copies to print, etc.

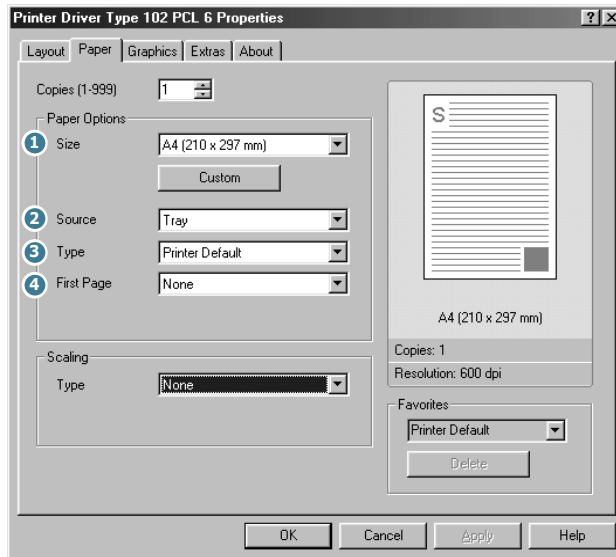

1 Select the size of paper you are using.

2 Select the desired paper source. Select **Tray** if you load media in the paper Tray, **Bypass Tray** if you load in the Bypass Tray.

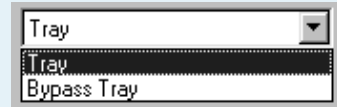

3 Select the type of paper you are using.

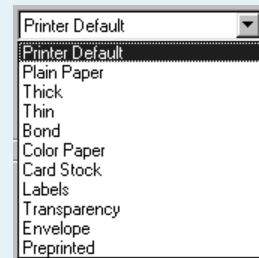

4 Select the desired paper source for the first page and other pages independently.



Printing Multiple Pages on One Sheet of Paper (N-Up Printing)

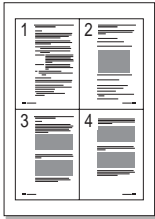

You can select the number of pages to print on a single sheet of paper. To print more than one page per sheet, the pages will appear decreased in size and arranged on the sheet. You can print up to 16 pages on one sheet.

- 1 To change the print settings from your software application, access the printer properties. See page 5.2.
- 2 From the **Layout** tab, choose **Multiple Pages per Side** on the **Type** drop-down list.
- 3 Select the number of pages you want to print per sheet (1, 2, 4, 6, 9 or 16) on the **Pages per Side** drop-down list.

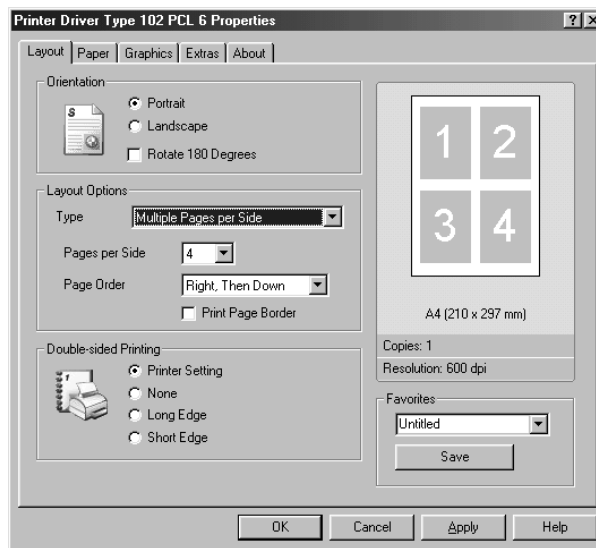

- 4 Select the page order on the **Page Order** drop-down list, if necessary.

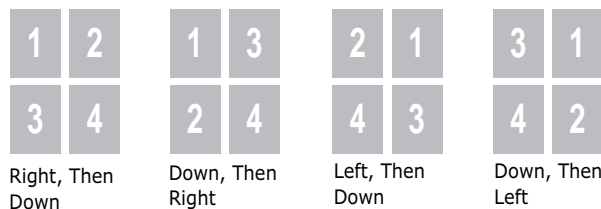

Check **Print Page Border** to print a border around each page on the sheet. **Print Page Border** is enabled only, if the pages per sheet is 2, 4, 6, 9 or 16.

- 5 Click the **Paper** tab and select the paper source, size and type.
- 6 Click **OK** and print the document.

Printing a Reduced or Enlarged Document

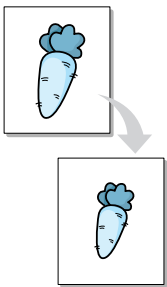

You can scale your print job on a page.

- 1 When you change the print settings from your software application, access the printer properties. See page 5.2.
- 2 From the **Paper** tab, select **Reduce/Enlarge** on the **Type** drop-down list.
- 3 Enter the scaling rate in the **Percentage** input box.

You can also click the ▲ or ▼ button.

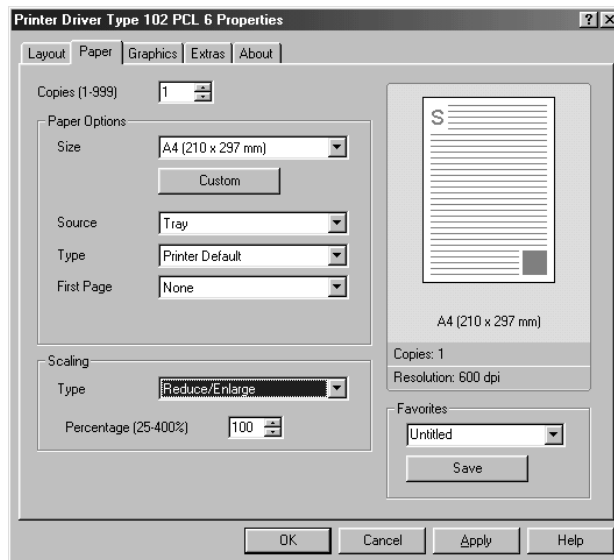

- 4 Click the **Paper** tab and select the paper source, size and type.
- 5 Click **OK** and print the document.

Fitting Your Document to a Selected Paper Size

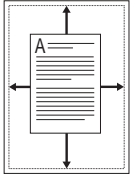

You can scale your print job to any selected paper size regardless of the digital document size. This can be useful when you want to check fine details on a small document.

- 1 When you change the print settings from your software application, access the printer properties. See page 5.2.
- 2 From the **Paper** tab, select **Fit to Page** on the **Type** drop-down list.
- 3 Select the correct size from the **Target Page** drop-down list.

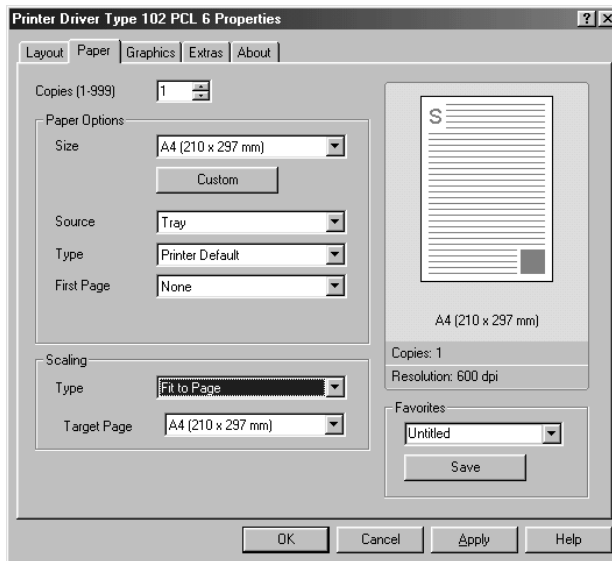

- 4 Click the **Paper** tab and select the paper source, size and type.
- 5 Click **OK** and print the document.

Printing Posters

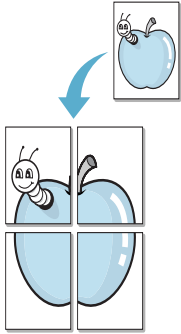

You can print a single-page document onto 4, 9 or 16 sheets of paper, for the purpose of pasting the sheets together to form one poster-size document.

- 1 When you change the print settings from your software application, access the printer properties. See page 5.2.
- 2 From the **Layout** tab, select **Poster** on the **Type** drop-down list.

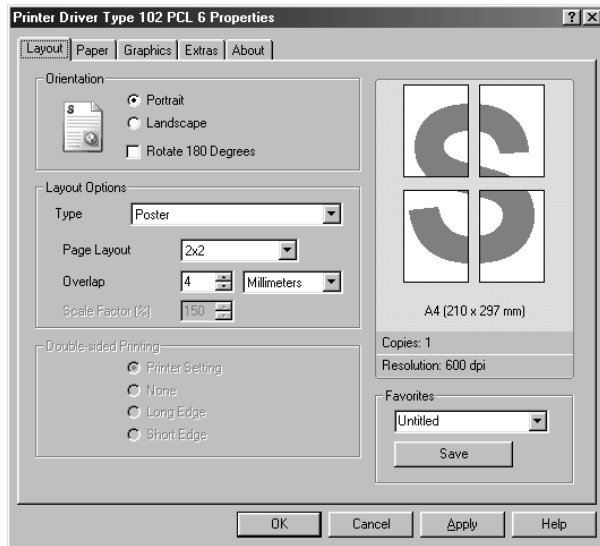

- 3 Configure the poster option:

You can select the page layout from 2x2, 3x3 or 4x4. If you select 2x2, the output will be automatically stretched to cover 4 physical pages.

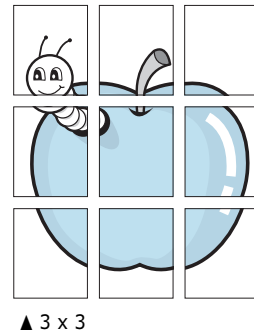
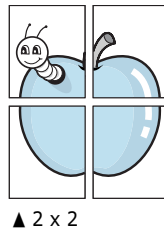

Specify an overlap in millimeters or inches to make it easier to reconstruct the resulting poster.

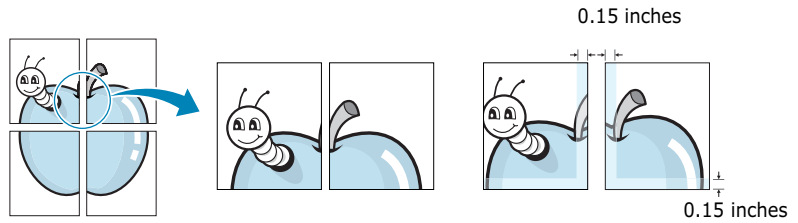

- 4 Click the **Paper** tab and select the paper source, size and type.
- 5 Click **OK** and print the document. You can complete the poster by reconstructing the results.

Using Watermarks



The Watermark option allows you to print text over an existing document. For example, you may want to have large gray letters reading "DRAFT" or "CONFIDENTIAL" printed diagonally across the first page or all pages of a document.

There are several predefined watermarks that come with your machine, and they can be modified or you can add new ones to the list.

Using an Existing Watermark

- 1 When you change the print settings from your software application, access the printer properties. See page 5.2.
- 2 Click the **Extras** tab and select a watermark on the **Watermark** drop-down list. It appears in the preview image window.

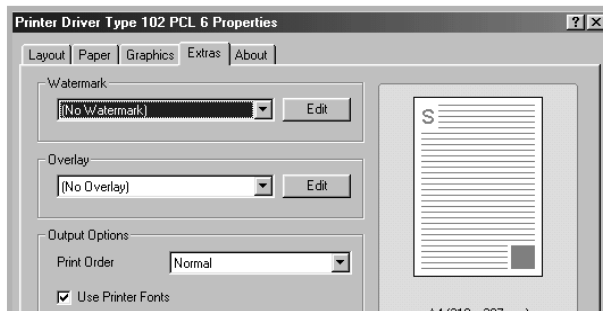

- 3 Click **Ok** and start printing.

Creating a Watermark

- 1 When you change the print settings from your software application, access the printer properties. See page 5.2.
- 2 Click the **Extras** tab and click the **Edit** button in the **Watermark** section. The Edit Watermarks window appears.

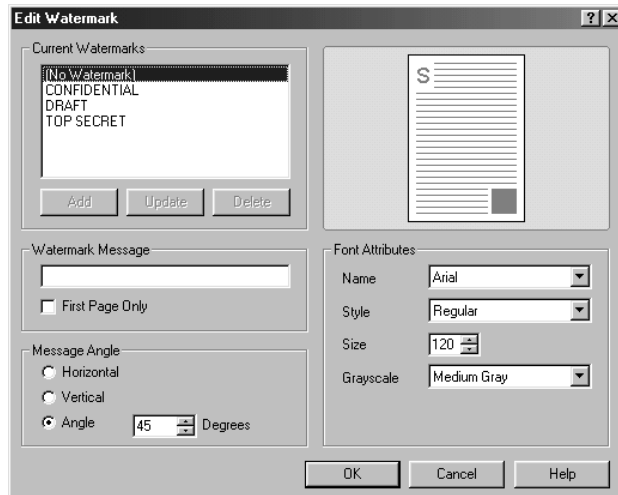

- 3 Enter the text message you want to print in the **Watermark Message** box.

The message displays in the preview image window. The preview image is provided so that you can see how the watermark will appear on the printed page.

When the **First Page Only** box is checked, the watermark is printed on the first page only.

- 4 Select the watermark options.

You can select the font name, style and size and gray scale level from the **Font Attributes** section and set the angle of the watermark from the **Message Angle** section.

- 5 Click **Add** to add a new watermark to the list.
- 6 When you finish creating, click **Ok** and start printing.

To stop printing the watermark, select **<No Watermark>** on the **Watermark** drop-down list.

Editing a Watermark

- 1 When you change the print settings from your software application, access the printer properties. See page 5.2.
- 2 Click the **Extras** tab and click the **Edit** button in the **Watermark** section. The Edit Watermarks window appears.
- 3 Select the watermark you want to edit on the **Current Watermarks** list, and change the watermark message and the options. Refer to “Creating a Watermark” on page 11.
- 4 Click **Update** to save the changes.
- 5 Click **Ok**.

Deleting a Watermark

- 1 When you change the print settings from your software application, access the printer properties. See page 5.2.
- 2 From the **Extras** tab, click the **Edit** button in the **Watermark** section. The Edit Watermarks window appears.
- 3 Select the watermark you want to delete on the **Current Watermarks** list and click **Delete**.
- 4 Click **Ok**.

Using Overlays

What is an Overlay?

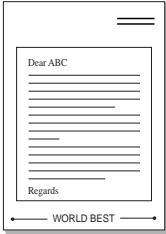

An overlay is text and/or images stored in the computer hard disk drive (HDD) as a special file format that can be printed on any document. Overlays are often used to take the place of preprinted forms and letterhead paper. Rather than using preprinted letterhead, you can create an overlay containing the exact same information that is currently on your letterhead. To print a letter with your company's letterhead, you do not need to load preprinted letterhead paper in the machine. You need only tell the machine to print the letterhead overlay on your document.

Creating a New Page Overlay



To use a page overlay, you must create a new page overlay containing your logo or image.

- 1 Create or open a document containing text or an image for use in a new page overlay. Position the items exactly as you wish them to appear when printed as an overlay. If needed, save the file for later use.
- 2 When you change the print settings from your software application, access the printer properties. See page 5.2.
- 3 Click the **Extras** tab and click **Edit** button in the **Overlay** section.

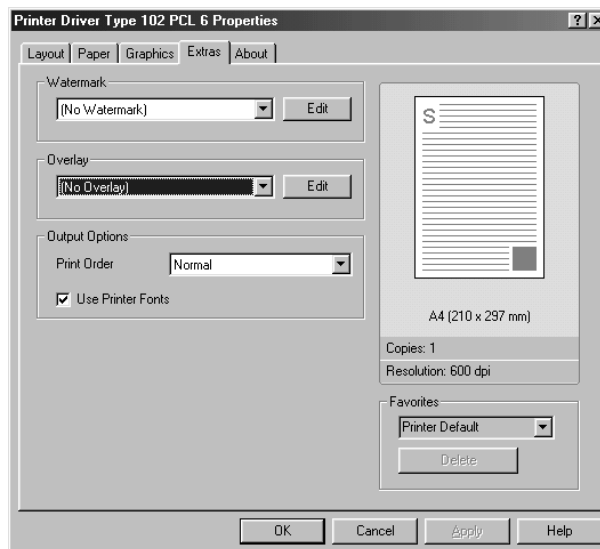

- 4 In the Edit Overlays window, click **Create Overlay**.

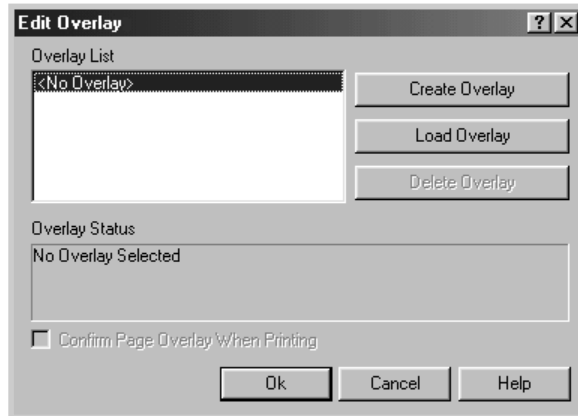

- 5 In the Create Overlay window, type a name of up to eight characters in the **File name** box. Select the destination path, if necessary. (The default is C:\Formover).

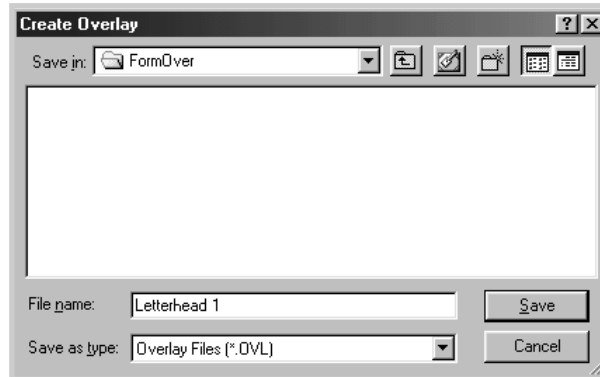

- 6 Click **Save**. You can see the name on the **Overlay List**.
- 7 Click **OK** or **Yes** until you complete creating.

The file is not printed out. Instead it is stored in your computer HDD disk.



NOTE: The overlay document size must be the same as document you will print with the overlay.

Using a Page Overlay

After an overlay has been created, it is ready to be printed with your document. To print an overlay with a document:

- 1 Create or open the document you want to print.
- 2 When you change the print settings from your software application, access the printer properties. See page 5.2.
- 3 Click the **Extras** tab.
- 4 Select the overlay you want to print from the **Overlay** drop-down list box.
- 5 When the overlay file doesn't appear on the **Overlay List**, click the **Edit** button and **Load Overlay**, and select the overlay file.

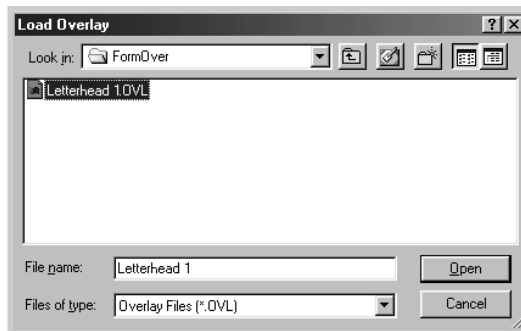

If you have stored the overlay file you want to use into an external source, you can also load the file when you access this Load Overlay window.

After you select the file, click **Open**. The file is now shown in the **Overlay List** box and is available for printing. Select the overlay from the **Overlay List** box.

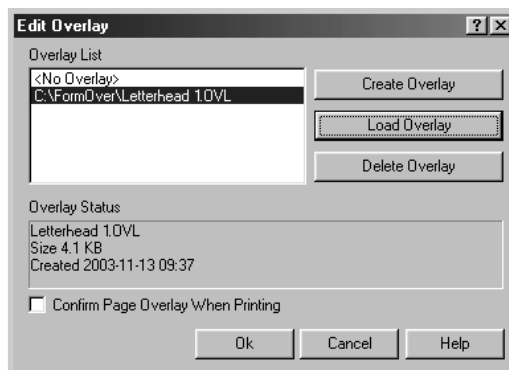

- 6 If necessary, click **Confirm Page Overlay When Printing**. When this box is checked, a message window appears each time you submit a document for printing, asking you to confirm your wish to print an overlay on your document.

Answering **Yes** to the window means that the selected overlay will be printed with your document. Answering **No** to the window cancels overlay printing.

If this box is empty and an overlay has been selected, the overlay will be automatically printed with your document.

- 7 Click **OK** or **Yes** until the printing starts.

The overlay is downloaded with your print job and printed on your document.



NOTE: The resolution of the overlay document must be the same as that of the document you will print with the overlay.

Deleting a Page Overlay

You can delete page overlays that are no longer used.

- 1 In the printer properties window, click the **Extras** tab.
- 2 Click **Edit** in the **Overlay** section.
- 3 Select the overlay you want to delete from the **Overlay List** box.
- 4 Click **Delete Overlay**.
- 5 Click **OK** until you exit the Print window.

Setting Graphic Properties

Use the following graphic options to adjust the print quality for your specific printing needs. See page 5.2 for more information about accessing printer properties.

Click the **Graphics** tab to display the properties shown below.

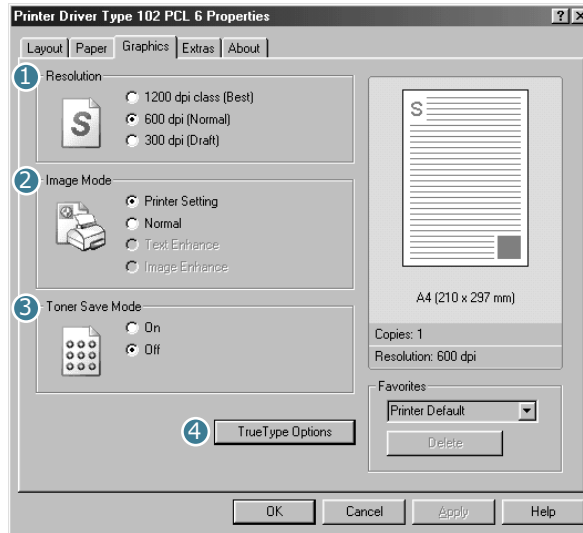

Property	Description
1 Resolution	You can select the printing resolution by choosing from 1200 dpi class (Best) , 600 dpi (Normal) or 300 dpi (Draft) . The higher the setting, the sharper the clarity of printed characters and graphics. Higher settings may increase time it takes to print a document.

Property	Description
<p>② Image Mode</p>	<p>When you print with the resolution of 300, 600, 1200 dpi, some printed characters or images can appear to have jagged or uneven edges. Set this Resolution enhancement Technology (RT) option to improve the print quality of your text and images, make the characters and images appear smoother.</p> <ul style="list-style-type: none"> • Printer Default - Choose this setting to use the RT that your printer provides. You can select this when resolution is 600/300 dpi. • Normal - Choose to disable RT mode. You can select this when resolution is 600/300 dpi. • Text Enhance - Choose to refine the print quality of characters by smoothing out jagged edges that can occur on the angles and curves of each character. You can select this when resolution is 1200/300 dpi. • Image Enhance - Choose to refine the print quality of photo images using RT. You can select this when resolution is 1200 dpi.
<p>③ Toner Save Mode</p>	<p>Selecting this option extends the life of your toner cartridge and reduces your cost per page without a significant reduction in the print quality.</p> <ul style="list-style-type: none"> • On: Select this option to allow the printer to use less toner on each page. • Off: When you do not need to save toner to print a document, select this option.

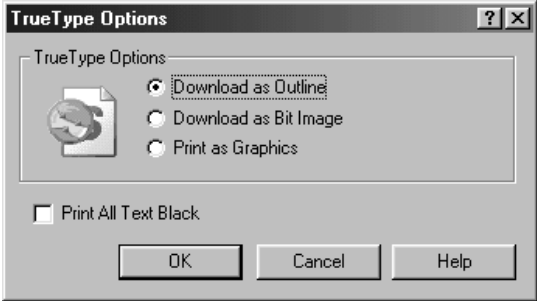
Property	Description
<p>4 TrueType Options</p>	<p>You can set TrueType settings by clicking the TrueType Options button.</p>  <p>True Type Options</p> <p>This option determines what the driver tells the machine about how to image the text in your document. Select the appropriate setting according to the status of your document.</p> <ul style="list-style-type: none"> • Download as Outline: When this option is selected, the driver will download any TrueType fonts that are used in your document not already stored (resident) on your printer. • Download as Bit Image: When this option is selected, the driver downloads the font data as bitmap images. Documents with complicated fonts, such as Korean or Chinese, or various types of fonts print faster in this setting. • Print as Graphics: When this option is selected, the driver downloads any fonts as graphics. When printing documents with high graphic content and relatively few TrueType fonts, printing performance (speed) may be enhanced in this setting. <p>Print All Text Black</p> <p>When the Print All Text Black option is checked, all text in your document is allowed to print solid black, regardless of the colour it appears on the screen. When it is not checked, coloured text is allowed to print in shades of gray.</p>

About Tab

The **About** tab gives you the program version number.

Printer Properties Buttons & Icons

- Click **OK** when you finish reviewing or making changes.
- Click **Cancel** if you want to exit the tab menus without applying any changes.
- Click **Help** to view the online Help feature and tab menu details.
- Click the **?** icon in the title bar to get information about specific setting on the page. Position the **?** pointer over the parameter in question and click to see a pop-up window for an explanation.

Setting Up the Locally Shared Printer

You can connect the machine directly to a selected computer, which is called "host computer," on the network. Your machine can be shared by other users on the network through a Windows 9x, Me, 2000, XP or NT 4.0 network printer connection.



NOTE: Whether the printer is locally connected or network-connected, you need to install the printer software on each computer that will print documents to the printer.

In Windows 9x/Me

Setting Up the Host Computer

- 1 Start Windows.
- 2 From the **Start** menu, select **Control Panel** and double-click on the **Network** icon.

- 3 Check the **File and Print Sharing** box and click **OK**.
- 4 Click **Start** and select **Printers** from **Settings**. Double-click your printer name.
- 5 Select **Properties** in the **Printer** menu.
- 6 Click the **Sharing** tab and check the **Shared As** box. Fill in the **Shared Name** field and then click **OK**.

Setting Up the Client Computer

- 1 Right-click **Start** and select **Explorer**.
- 2 Open your network folder in the left column.
- 3 Right-click the shared name and select **Capture Printer Port**.
- 4 Select the port you want, check the **Reconnect at log on** box and then click **OK**.
- 5 From the **Start** menu, select **Settings** and then **Printers**.
- 6 Double-click your printer icon.
- 7 From the **Printer** menu, select **Properties**.
- 8 From the **Details** tab, select the printer port and click **OK**.

In Windows NT 4.0/2000/XP

Setting Up the Host Computer

- 1 Start Windows.
- 2 For Windows NT 4.0/2000, from the **Start** menu, select **Settings** and then **Printers**.

For Windows XP, from the **Start** menu, select **Printers and Faxes**.

- 3** Double-click your printer icon.
- 4** From the **Printer** menu, select **Sharing**.
- 5** For Windows NT 4.0, check the **Shared** box.
For Windows 2000, check the **Shared As** box.
For Windows XP, check the **Share this printer** box.
- 6** For Windows NT 4.0, fill in the **Share Name** field and click **OK**.
For Windows 2000/XP, fill in the **Shared Name** field and click **OK**.

Setting Up the Client Computer

- 1** Right-click **Start** and select **Explorer**.
- 2** Open your network folder in the left column.
- 3** Click the shared name.
- 4** For Windows NT 4.0/2000, from the **Start** menu, select **Settings** and **Printers**.
For Windows XP, from the **Start** menu, select **Printers and Faxes**.
- 5** Double-click your printer icon.
- 6** From the **Printer** menu, select **Properties**.
- 7** Press the **Ports** tab and click **Add Port**.
- 8** Select **Local Port** and click **New Port**.
- 9** Fill in the **Enter a port name** field and enter the shared name.
- 10** Click **OK** and click **Close**.
- 11** For Windows NT 4.0, click **OK**.
For Windows 2000/XP, click **Apply** and click **OK**.



6

SCANNING

Scanning with your machine lets you turn pictures and text into digital files on your computer.

This chapter includes:

- **Scanning Process with TWAIN-enabled Software**

Scanning Process with TWAIN-enabled Software

If you want to scan documents using other software, you will need to use TWAIN-compliant software, such as Adobe PhotoDeluxe or Adobe Photoshop. The first time you scan with your machine, you will need to select it as your TWAIN source in the application you will use.

The basic scanning process involves a number of steps:

- Place your photograph or page on the document glass.
- Open an application, such as PhotoDeluxe or Photoshop.
- Open the TWAIN window and setting the scan options.
- Scan and save your scanned image.

You need to follow the program's instructions for acquiring an image. Please refer to the Operating Instructions for the application.



7

MAINTENANCE

This chapter provides information for maintaining the cartridge and your machine.

This chapter includes:

- **Cleaning the Scan Unit**
- **Expected Cartridge Life**
- **Replacing the Toner Cartridge**
- **Setting to Notify Toner Low**
- **Cleaning the Drum**
- **Replacing the Drum Cartridge**
- **Setting the machine to be Checked by Phone**

Cleaning the Scan Unit

Keeping the scan unit clean helps ensure the best possible copies. We suggest that you clean the scan unit at the start of each day and during the day as needed.



NOTE:

- Cleaning the cabinet of the printer with surfactants containing large amounts of alcohol, solvent or other strong substances can discolor or crack the cabinet.
 - Clean the cabinet of the printer with a soft, lint-free cloth. You can dampen the cloth slightly with water, but be careful not to let any water drip onto the printer or inside of it.
-

- 1 Slightly dampen a soft lint-free cloth or paper towel with water.
- 2 Open the document cover.
- 3 Wipe the surface of the document glass and ADF glass until it is clean and dry.

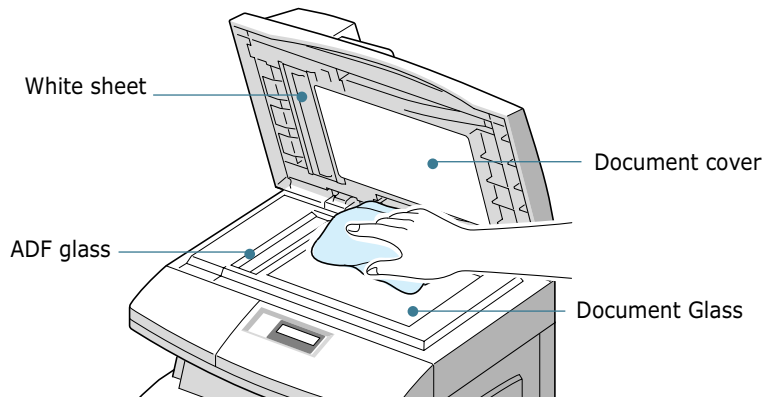

- 4 Wipe the underside of the white document cover and white sheet until it is clean and dry.
- 5 Close the document cover.

Expected Cartridge Life

The life of your toner cartridge depends on the amount of toner used in each print job. For instance, when you print a typical business letter with about 5% page coverage, you can expect a toner cartridge life of approximately 6,000 pages. (The original toner cartridge supplied with the printer lasts an average of 3,000 pages.) The actual number may vary according to the print density of the page you print. If you print a lot of graphics, you may need to change the cartridge more often.

Replacing the Toner Cartridge

When the toner cartridge is near the end of its life, white streaks or light copy will occur. The LCD displays a warning message "TONER LOW." You can temporarily re-establish the print quality by re-distributing the remaining toner in the cartridge. To do this:

- 1 Pull the release lever to open the side cover.

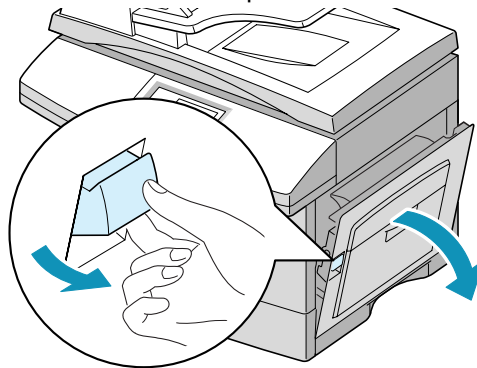

- 2 Open the front cover.

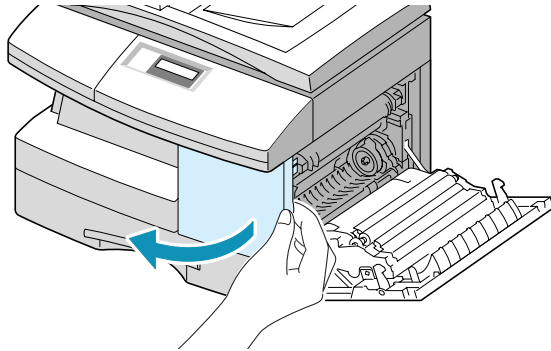

- 3 Turn the cartridge locking lever upwards to release the toner cartridge.

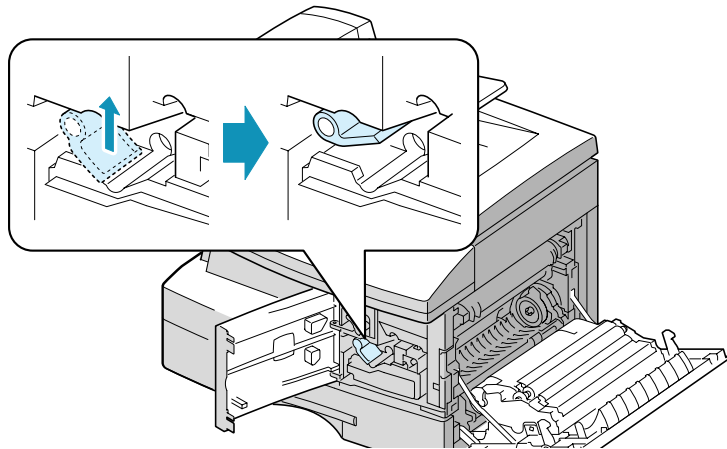

- 4 Pull the toner cartridge out and gently shake the cartridge to distribute the toner evenly inside the cartridge.

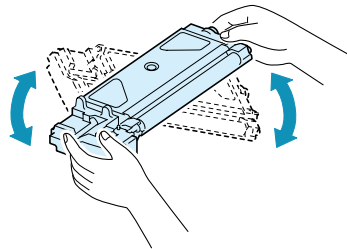

NOTE: If the toner gets on your clothing, wipe it off with a dry cloth and wash clothing in cold water. Hot water sets the toner into fabric.

- 5 Reinstall the cartridge and turn the cartridge locking lever downwards.
- 6 Close the front cover, then the side cover. The display shows "NEW TONER? 1.YES 2.NO."
- 7 Select "NO" by pressing **2**. The machine returns to Standby mode. This is typically successful only one time.

When the toner eventually runs out, only blank pages will print when a print job is sent, or when a fax is received. At this stage, the toner cartridge needs to be replaced. The display shows the warning message "TONER EMPTY."

Take the following steps to replace the toner cartridge:

- 1 The side cover must be open to open the front cover.

Make sure that the side cover is open before opening the front cover.

- 2 Turn the cartridge locking lever upwards to release the toner cartridge.

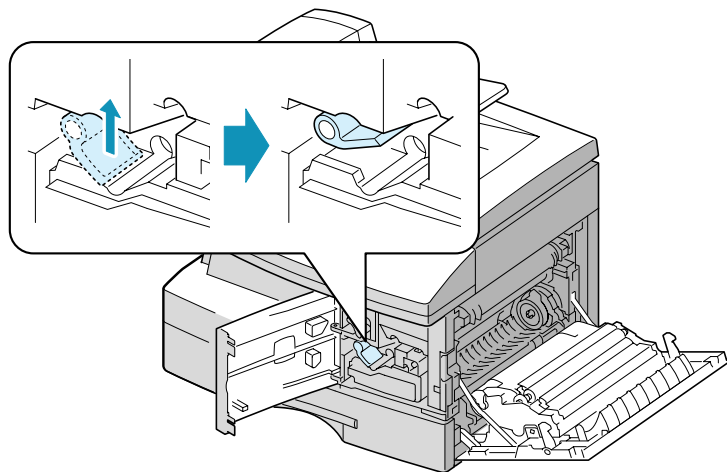

- 3 Pull the used cartridge out.

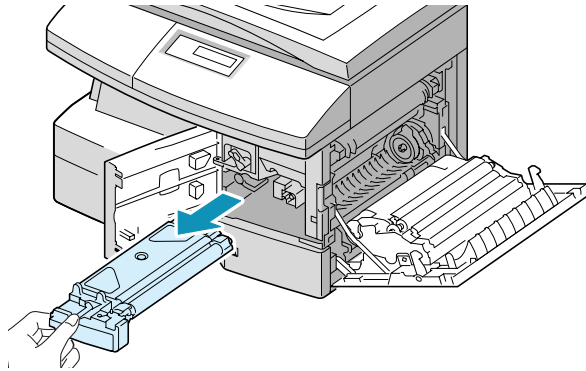

NOTE: Help the environment by recycling your used toner cartridge. Refer to the recycling brochure packed with the toner cartridge for details.

- 4 Shake the new toner cartridge horizontally four or five times.

Save the box and the cover for shipping.

- 5 Slide the new toner cartridge in until it locks in place.

- 6 Turn the cartridge locking lever downwards until it locks in place.

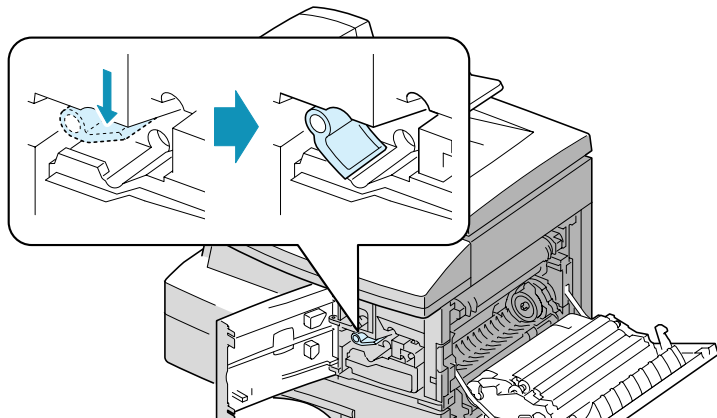

- 7 Close the front cover, then the side cover. The display shows "NEW TONER? 1.YES 2.NO".

- 8 Select "YES" by pressing **1**. The machine returns to Standby mode.

Setting to Notify Toner Low

If you have set this NOTIFY TONER LOW menu option to "ON," your machine automatically sends a fax to your service company or the dealer to notify them that your machine requires a new toner cartridge when the toner cartridge needs to be replaced. The fax number is preset by your dealer when you bought your machine.

- 1** Press **Menu/Exit** and then **Maintenance** from the one-touch dial keypad.
- 2** Use \triangle or ∇ until "NOTIFY TONER" appears on the bottom line of the display, and press **Mode/Enter**.

"NOTIFY TONER LOW" appears on the top line and the current setting appears on the bottom line.
- 3** Press \triangleleft or \triangleright to change the setting. Select "ON" to enable this feature, then press **Mode/Enter**.

Select "OFF" disables this feature.
- 4** Enter your fax number, and then press **Mode/Enter**.
- 5** Enter your name of up to 20 digits, and then press **Mode/Enter**.
- 6** Enter the service company's phone number to which your machine sends the fax message to notify Toner Low, and then press **Mode/Enter**.
- 7** Enter the serial number of your machine, and then press **Mode/Enter**.

Cleaning the Drum

If there are streaks or spots on your print, the drum cartridge may require cleaning.

- 1 Before setting the cleaning procedure, make sure that paper is loaded in the machine.
- 2 Users should press **Menu/Exit** then **Maintenance** from the one-touch dial keypad.
- 3 "CLEAN DRUM" appears on the bottom line of the display. Press **Mode/Enter**.
- 4 The machine prints out a cleaning page. Toner particles on the drum surface are affixed to the paper. Repeat this process three or four times.

Replacing the Drum Cartridge

The useful life of the drum cartridge is approximately 15,000 copies. The LCD displays "DRUM WARNING" when the drum is near the end of life. Approximately 1,000 more copies can be made, but you should have a replacement drum cartridge in stock. When "DRUM EMPTY" is displayed, the machine will stop operating until the drum cartridge is replaced.

To replace the drum cartridge:

- 1 Open the side cover, then the front cover.
The side cover is open before opening the front cover.

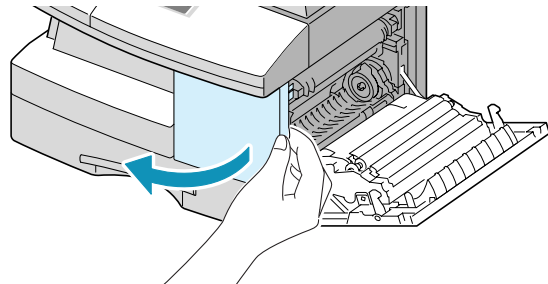

- 2 Turn the cartridge locking lever upwards to unlock the toner cartridge, then pull the toner cartridge out.

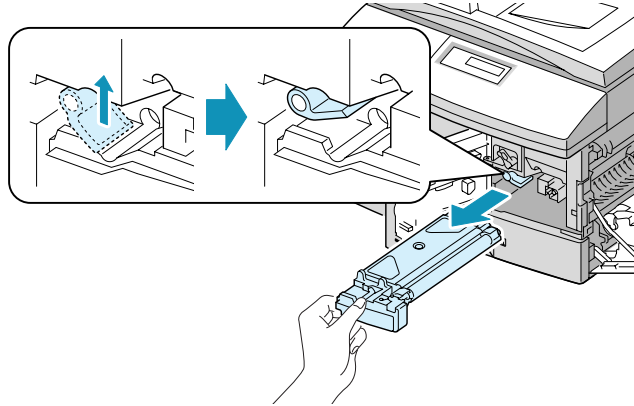

NOTE: The toner cartridge must be removed to replace the drum cartridge.

- 3 Pull the used drum cartridge out.

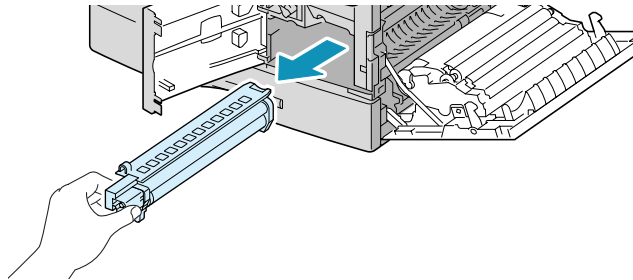

NOTE: Help the environment by recycling your used drum cartridge. Refer to the recycling brochure packed with the drum cartridge for details.

- 4 Unpack the new drum cartridge and slide it into place, making sure not to touch the surface of the drum.

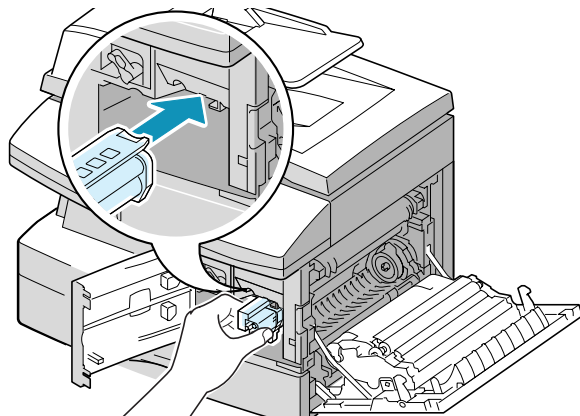

- 5 Reinstall the toner cartridge, and then lock the lever.

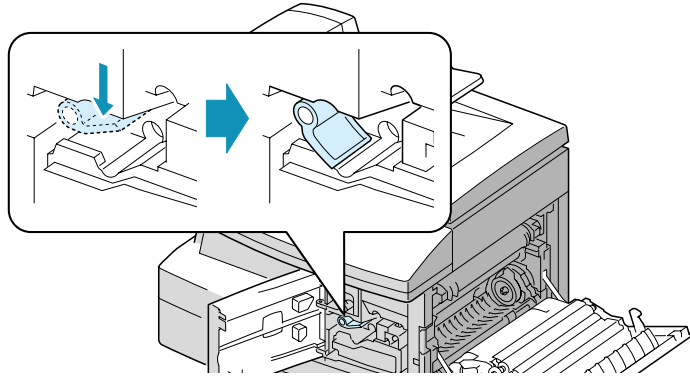

NOTE: If your machine automatically recognises the replaced cartridge, you can skip steps 6 and 7.

- 6 Close the front cover and the side cover. The LCD displays "NEW DRUM? 1.YES 2.NO".
- 7 Select "YES" by pressing **1**. The machine returns to Standby mode.

If the drum cartridge does not work properly and you have to replace it with a new one before "DRUM WARNING" or "DRUM EMPTY" may appears on the display, replace the drum cartridge as described above then take the following steps to reset the drum counter:

- 1 Press **Menu/Exit** then **Maintenance** from the one-touch dial keypad.
- 2 Use Δ or ∇ until "NEW DRUM" appears on the bottom line of the display, and press **Mode/Enter**.
- 3 "NEW DRUM UNIT?" appears on the top line and "1.YES 2.NO" appears on the bottom line. Press **1** to select "1.YES."



NOTE: If you do not reset the counter, "DRUM WARNING" or "DRUM ENPTY" may appear before the current drum cartridge's time is up.

Setting the machine to be Checked by Phone

The Remote Test feature allows your machine to be checked out by a service company at a remote place by phone.

1 Press **Menu/Exit** and then **Maintenance** from the one-touch dial keypad.

2 Use \triangle or ∇ until "REMOTE TEST" appears on the bottom line of the display, and press **Mode/Enter**.

3 Press \triangleleft or \triangleright to change the setting.

Select "On" to enable this feature. Selecting "Off" disables this feature.

If you want to protect your machine from being opened by an unauthorized person, select "Off".

4 Press **Mode/Enter** to save the selection.



NOTE: This feature is not available in some areas.

MEMO



8

TROUBLESHOOTING

This chapter gives helpful information for what to do if you encounter an error.

This chapter includes:

- **Document Jams**
- **Paper Jams**
- **LCD Error Messages**
- **Solving Problems**

Document Jams

If a document jams while it is feeding through the ADF, "DOCUMENT JAM" appears on the display.

Details for clearing the three types of document misfeeds are given below.

Input Misfeed

- 1 Open the ADF top cover.

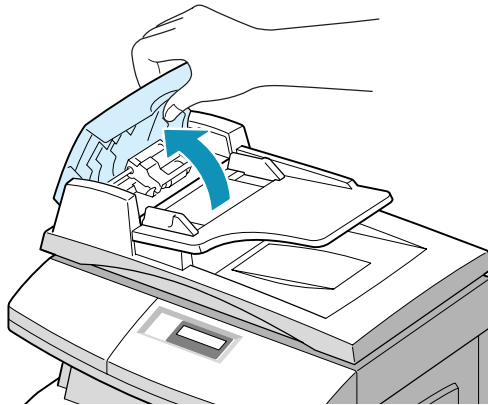

- 2 Pull the document gently to the right and out of the ADF.

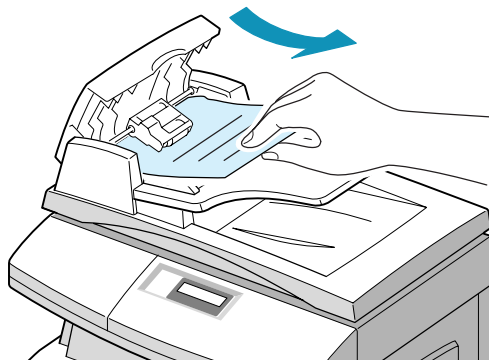

- 3 Close the ADF top cover. Then place the documents back into the ADF.



NOTE: To prevent document jams, use the document scanner glass for thick, thin or mixed documents.

Exit Misfeed

- 1 Open the document cover and turn the release knob to remove the misfed documents from the exit area.

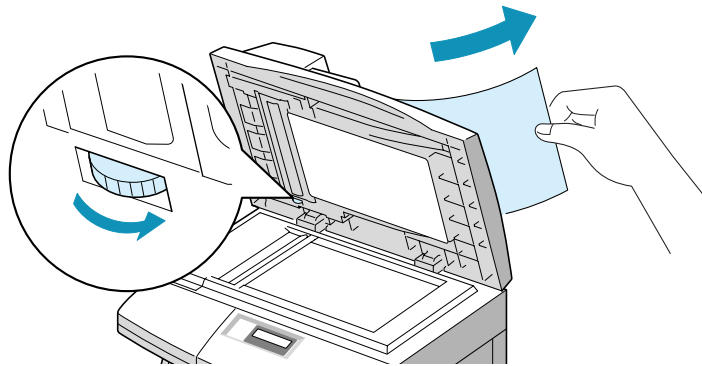

- 2 Close the document cover. Then place the documents back into the ADF.

Roller Misfeed

- 1 Open the document cover.
- 2 Turn the release knob so that you can easily seize the misfed document, and remove the document from the ADF or the feed area by carefully pulling it rightwards using both hands.

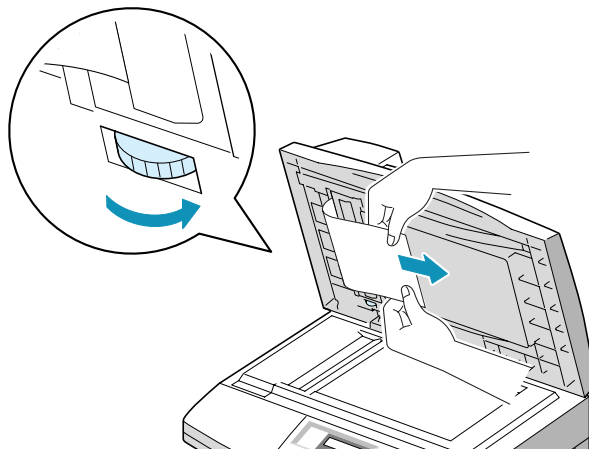

- 3 Close the document cover. Then place the documents back into the ADF.

Paper Jams

If paper jams occur, "PAPER JAM" appears on the display. Follow the steps below to clear the jam. To avoid tearing the paper, pull the jammed paper out gently and slowly.

Paper Feed Area

If the paper jammed in the feed area, "PAPER JAM0" appears in the display.

- 1 Pull the paper Tray open. After you pull it out completely, lift the front part of the Tray slightly up to release the Tray from the machine.

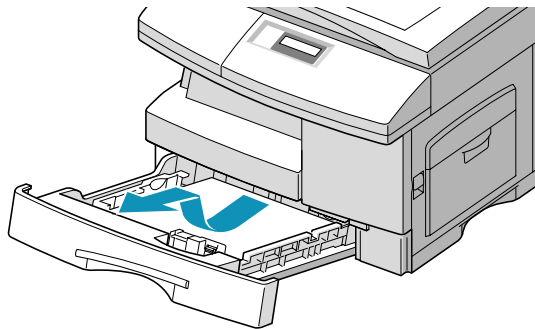

- 2 Remove the jammed paper by gently pulling it straight out.

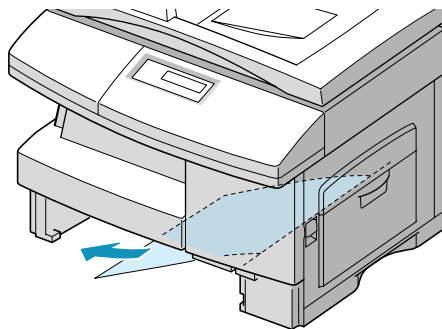

Once you remove the jammed paper here, open the side cover and then close it to clear the "PAPER JAM" message on the display.

If there is any resistance, and the paper does not move immediately when you pull, stop pulling. Then:

- 3 Pull the release lever to open the side cover.



NOTE: Do not touch the shiny drum cartridge surface. Scratches or smudges will result in poor copy quality.

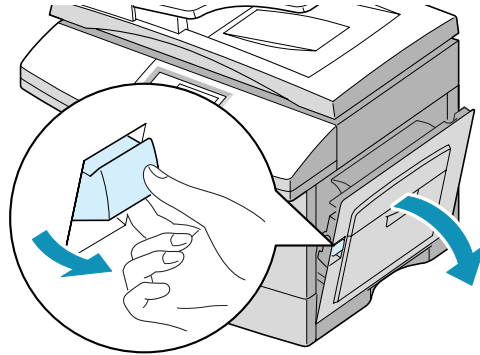

- 4 Carefully remove the misfed paper in the direction shown.

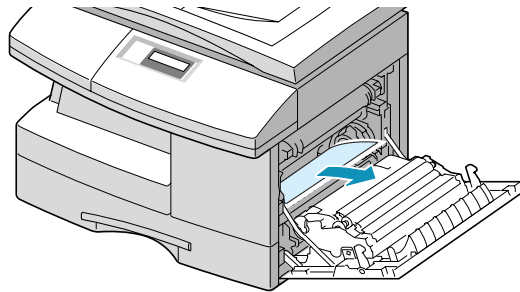

- 5 Close the cover and insert the paper Tray. Lower the rear part of the Tray to align the rear edge to the corresponding slot of the machine, then insert it completely.

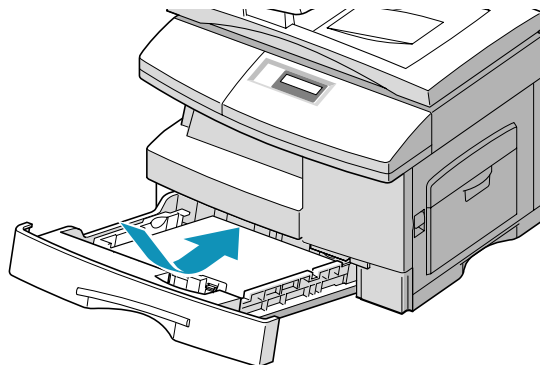

Fuser Area

If the paper jammed in the fuser area, "PAPER JAM 1" appears on the display:

- 1 Lift the release lever to open the side cover.
- 2 Pull down on the fuser lever as shown below. This will release pressure on the paper.

If paper is not seen in this area, skip to the Exit Area.

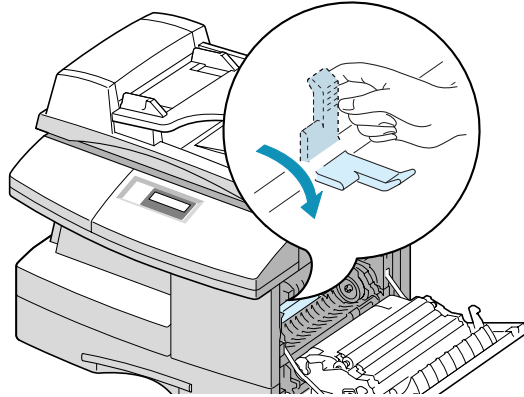

WARNING: The fusing area at the rear part of the inside of your machine is hot when powered. Be careful not to be burned when you access this area.

- 3 Remove the jammed paper, in the direction shown.

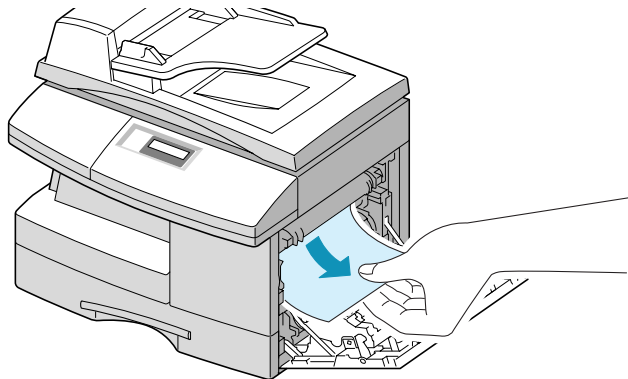

NOTE: Do not pull paper up through the fusing unit. Unfused toner may adhere in the area, resulting in smudged copies.

- 4 Push the fuser lever up, and then close the side cover.

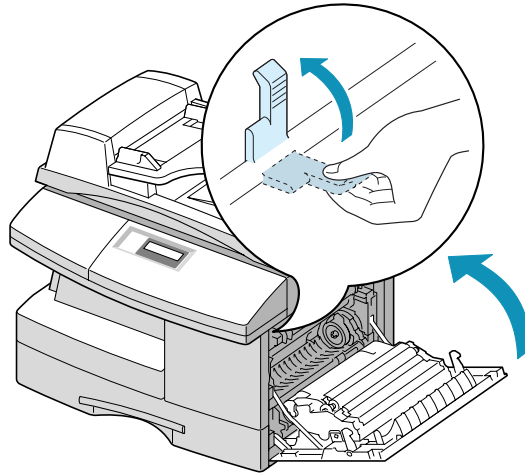

Paper Exit Area

If the paper jammed in the exit area, "PAPER JAM 2" appears on the display.

- 1 Press the release lever to open the side cover.
- 2 Open the front cover.

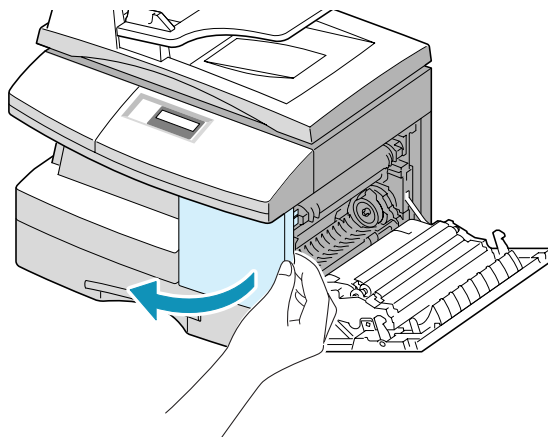

- 3** Pull down on the fuser lever. This will release pressure on the paper.

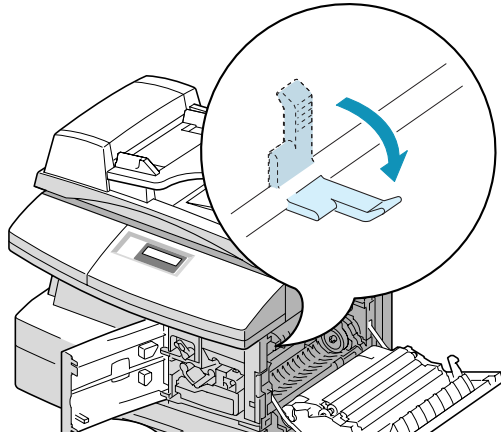

- 4** Turn the Jam Remove Lever in the direction of the arrow to move the paper to the exit area, then gently pull the paper out through the exit area.

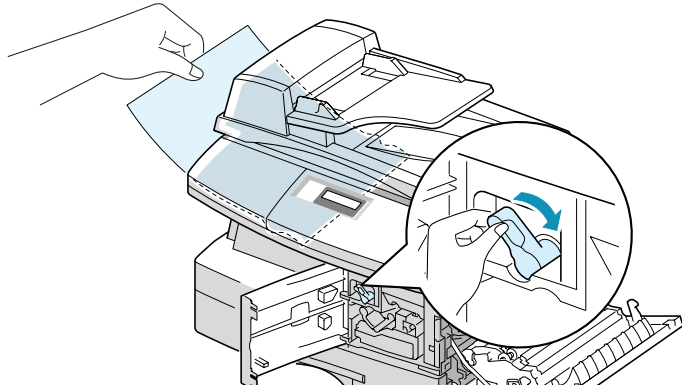

- 5** Push the fuser lever up.

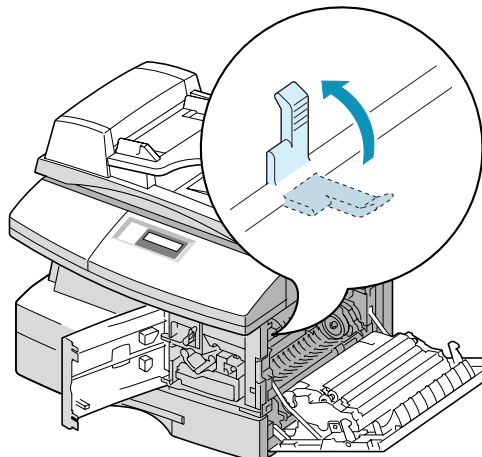

- 6 Turn the Jam Remove Lever back to the original position.

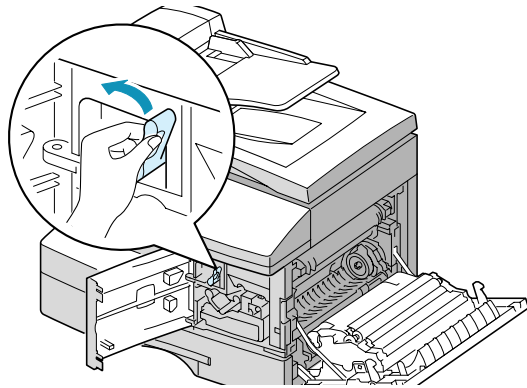

- 7 Close the front cover ❶ and the side cover ❷.

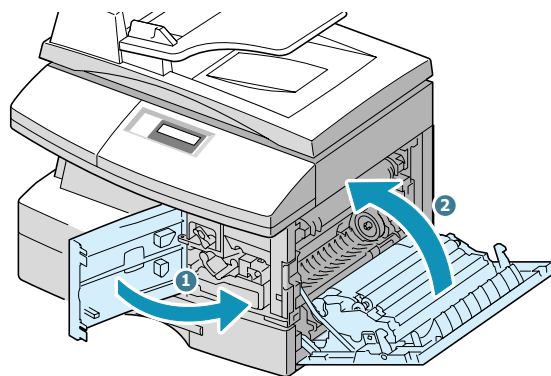

Duplex Jam

If paper jam occurs in the duplexer, "DUPLEX JAM" appears on the display.

- 1 Press the release lever to open the side cover.
- 2 Remove the jammed paper. Then close the side cover.

Bypass Tray Jam

"BYPASS JAM" appears on the display when you try to print using the Bypass Tray and the machine does not detect paper due to no paper or improper paper loading.

"BYPASS JAM" also may occur when the paper is not properly fed into the machine through the Bypass Tray. In that case, pull the paper out of the machine.

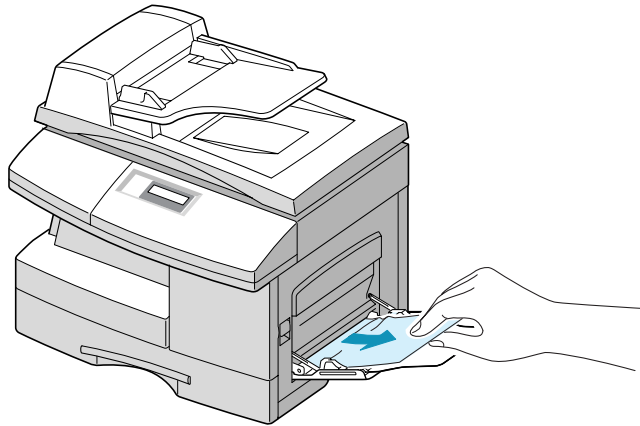

LCD Error Messages

Display	Meaning	Solution
BYPASS JAM	The machine detects no feeding from the Bypass Tray.	Load paper in the Bypass Tray.
DOCUMENT JAM	The loaded document has jammed in the ADF.	Clear the document jam. See page 8.2.
DOOR OPEN	The side cover is not securely latched.	Close the side cover until it locks into place.
DRUM WARNING	The drum cartridge is near the end of its life.	You should have a replacement cartridge in stock.
DUPLEX JAM	Paper has jammed in the middle of a 2-sided print job.	Clear the jam. See page 8.9.
DRUM EMPTY	The drum cartridge is empty.	Replace the drum cartridge. See page 7.8.
FUSER ERROR	There is a problem in the fuser unit.	Unplug the power cord and plug it back in. If the problem still persists, please call for your sales or service representative.
OPEN HEAT ERROR		
HEATING ERROR		
OVER HEAT		
INVALID CARTRIDGE	You have used an unauthorised cartridge.	You must use a approved cartridge.
LINE ERROR	Your machine cannot connect with the remote machine, or has lost contact because of a problem with the phone line.	Try again. If the problem persists, wait an hour or so for the line to clear, then try again. Or, turn the ECM mode on. See 'System Data Options' in the Facsimile Reference.
LSU ERROR	A problem has occurred in the LSU (Laser Scanning Unit).	Unplug the power cord and plug it back in. If the problem still persists, please call for your sales or service representative.

Display	Meaning	Solution
MEMORY FULL	The memory is full.	Either delete unnecessary documents, retransmit after more memory becomes available, or split the transmission into more than one operation.
NO ANSWER	The remote fax machine has not answered after several redial attempts.	Try again. Make sure the remote machine is operational.
POLLING ERROR	The remote fax machine you want to poll is not ready to respond to your poll. Or, when setting up to poll another fax machine, you have used an incorrect poll code.	The remote operator should know in advance that you are polling and have the fax machine loaded with the original document. Enter the correct poll code.
NO DEVELOPER CARTRIDGE	The drum cartridge is not installed.	Install the drum cartridge.
NO PAPER	The paper in the paper Tray has run out.	Load paper in the paper Tray.
RX TRAY FULL	Paper is overstacked in the output bin.	Remove paper.
PAPER JAM 0	Paper has jammed in the paper feeding area of the Tray.	Clear the jam. See page 8.4.
PAPER JAM 1	Paper has jammed in the fuser area.	Clear the jam. See page 8.6.
PAPER JAM 2	Paper has jammed in the paper exit area.	Clear the jam. See page 8.7.
RETRY REDIAL?	The machine is waiting for a specified time interval to redial a previously busy station.	You can press Mode/Enter to immediately redial, or Clear/Stop to cancel the redial operation.
SCANNER LOCKED	The scan module is locked.	Unlock the scanner (see page 1.2) and press Clear/Stop .

Display	Meaning	Solution
TONER EMPTY	The toner cartridge has run out. The machine stops.	Replace with a new toner cartridge. See page 7.3.
TONER LOW	The toner is almost empty.	Take out the toner cartridge and gently shake it. By doing this, you can temporarily re-establish printing operations.

Solving Problems

The following chart lists some conditions that may occur and the recommended solutions. Follow the suggested solutions until the problem is corrected. If the problem persists, please contact a service engineer.

Copier Problem Solution Chart

Condition	Suggested solutions
The LCD does not turn on.	Check that the machine is plugged into an electrical supply. Ensure that there is power to the socket where the unit is plugged in to and that the machine power switch is in the ON position.
The machine beeps an error sound and does not make a copy.	Make sure that the machine is in copy mode. If not, change the mode to the Copy mode by pressing Mode/Enter .
Copies are too light or too dark.	If the original is light, use the Contrast button to darken the background of the copies. If the original is dark, use the Contrast button to lighten the background of the copies.
Smears, lines, marks, or spots on copies.	If the defects are on the original, press the Contrast button to lighten the background of your copies. If no defects are on the original, clean the document glass and underside of the document cover.
White or black lines on your copy.	Check to see if the temperature is too low. When it is lower than 10 °C , copy your document 1 hour after you turn the machine on.

Condition	Suggested solutions
Copy image is skewed.	<p>Ensure that original is positioned correctly on document glass.</p> <p>Check that the copy paper is loaded correctly.</p>
Blank copies.	<p>Ensure that the original is face down on the document glass or face up in the ADF.</p>
Image rubs off the copy easily.	<p>Replace the paper in the Tray with paper from a new package.</p> <p>In high humidity areas do not leave paper in the machine for extended periods of time.</p>
Frequent copy paper jams.	<p>Fan the stack of paper, then turn it over in the Tray. Replace the paper in paper Tray with a fresh supply. Check/adjust the paper guides, if necessary.</p> <p>Ensure that the paper is the proper paper weight. 20 lb (75 g/m²) bond paper is recommended. Check for copy paper or pieces of copy paper remaining in the machine after a paper jam has been cleared.</p>
Toner yield is lower than expected and TONER LOW message appears on the LCD.	<p>Toner may be lodged in the cartridge. Remove the toner cartridge. Shake the toner cartridge and tap along the top of the toner cartridge over a waste receptacle. Take care not to touch the exposed toner on the left side of the cartridge.</p>
Fewer copies from the toner cartridge than expected.	<p>Your originals may contain pictures, solids, or heavy lines, for example, forms, newsletters, books or other documents that use more toner. The machine may be turned frequently on and off. The document cover is being left open while copies are being made.</p>
The following message appears on your computer screen: Scanner is busy receiving or printing data. When the current job is completed, try again.	<p>There may be a copying or printing job in progress. When the current job is completed, try the job again.</p>

Printing Problem Solution Chart

Condition	Probable cause	Suggested solutions
Your machine does not print.	The IEEE 1284 parallel cable or USB cable is not connected properly.	Check the cable connection.
	The IEEE 1284 parallel cable or USB cable is defective.	Check the cable with a computer and printer that work. If printing is still not possible, replace the cable.
	The port setting is incorrect.	Check the printer settings in the Windows Control Panel to make sure that the print job is being sent to the correct port. (For Example: LPT1.)
Your machine does not print. (continued)	The toner and drum cartridges are not installed properly.	Check that the toner and drum cartridges are installed properly.
	The printer driver may not be installed properly.	Reinstall the software.
	The parallel port cable specifications may not be correct.	Use the IEEE 1284 parallel port cable supplied with the machine or replace it with an IEEE 1284 compliant cable.
Half of the page is blank.	The page layout is too complex.	Reduce the resolution setting from 600 dpi to 300 dpi. Install more RAM in the computer.
	The page orientation may be incorrect.	Change the page orientation in the printer setup dialogue.

Condition	Probable cause	Suggested solutions
When printing using the USB connection, an error occurs repeatedly.	When the USB mode is set to "FAST" some PC users may experience poor USB communication.	<p>Change the USB mode to "SLOW." To do so, take the following steps:</p> <ol style="list-style-type: none"> 1. Press Menu/Exit then System Setup from the one-touch dial keypad. 2. Use \triangle or ∇ until "USB MODE" appears on the top line of the display. The current setting appears on the bottom line. 3. Press \triangleleft or \triangleright to select "SLOW." 4. Press Mode/Enter to save the selection. 5. Press Clear/Stop to return to Standby mode.
Printing is too slow.	The computer parallel port may not be set for high speed communications.	If your computer is equipped with an ECP parallel port, enable this mode of operation. Refer to the Enabling High Speed Printer Communications section and your computer's user guide.
	If using Windows 95, the spool setting may be set incorrectly.	Point to the Start and then click Settings then Printers . Click your printer icon with the right mouse button. Click Properties and then spool settings on the Details tab. Select the desired setting from the available choices.
	Computer may not have enough memory (RAM).	Install more RAM in your computer.
	The print job is large.	Reduce resolution from 600 dpi to 300 dpi.

Condition	Probable cause	Suggested solutions
Irregular faded patches of print.	There is a paper quality problem.	Use only paper that meets the specifications required by the machine.
	Toner may be unevenly distributed.	Remove the toner cartridge and shake it gently to evenly distribute the toner. Then reinstall the toner cartridge.
Black staining	There is a paper quality problem.	Use only paper that meets the specifications required by your machine.
Character voids	The paper may be too dry.	Try printing with a different batch of paper.
Background scatter	The paper may be too damp.	Try printing with a different batch of paper. Do not open packets of paper until necessary so that the paper does not absorb too much moisture from the air.
	Printing over uneven surfaces.	If printing onto envelopes, change your printing layout to avoid printing over areas that have overlapping seams on the reverse side.
Missing characters	The paper may be too damp.	Try printing with a different batch of paper. Do not open packets of paper until necessary so that the paper does not absorb too much moisture from the air.
Back of printout is dirty	The transfer roller may be dirty.	Print a few blank pages to clean the transfer roller.
Faded graphics	Toner may be low.	Remove the toner cartridge and shake it gently to evenly distribute the toner. Then reinstall the toner cartridge. Ensure that you have a spare toner cartridge.

Fax Problem Solution Chart

Condition	Suggested solutions
The machine is not working, there is no display and the buttons are not working.	<p>Unplug the power cord and plug it in again.</p> <p>Check that your socket is Live.</p>
No dial tone	<p>Check that the phone line is connected properly.</p> <p>Check that the phone socket on the wall is working by plugging in another phone.</p>
The numbers stored in the memory do not dial correctly.	Make sure that the numbers are stored in the memory correctly. Print a Phone Book list referring to the Facsimile Reference.
The document does not feed into the machine.	<p>Make sure that the document is not wrinkled and you are putting it in correctly. Check that the document is the right size, not too thick or thin.</p> <p>Make sure that the ADF top cover is firmly closed.</p>
Faxes are not received automatically.	<p>The FAX mode should be selected.</p> <p>Make sure that there is paper in the Tray.</p> <p>Check if the display shows "MEMORY FULL."</p>
Faxes are not received manually.	Check that you hung up the handset of the external telephone before you started faxing.
Your machine will not send anything.	<p>Make sure that the document is loaded face down/up depending on whether you are using the Document scanner glass or ADF unit.</p> <p>"TX" should show up on the display.</p> <p>Check the other fax machine you are sending to, to see if it can receive your fax.</p>
You cannot poll another machine.	The fax machine you are polling may be using a poll code. Contact the remote operator.

Condition	Suggested solutions
<p>The incoming fax has blank spaces or you received a poor-quality copy.</p>	<p>The fax machine sending you the fax may be faulty.</p> <p>The fax machine sending you a fax may have a dirty document glass. Clean the document glass, referring to page 7.2.</p> <p>A noisy phone line can cause line errors.</p> <p>Check your machine by making a copy.</p> <p>The toner cartridge may be empty. Replace the toner cartridge, referring to page 7.3.</p>
<p>Some of the words are stretched on the incoming fax.</p>	<p>The fax machine sending you the fax had a temporary document jam.</p>
<p>There are lines on the copies or documents you send.</p>	<p>Check your scan glass for marks, and clean it. See page 7.2.</p>
<p>The machine dials a number, but fails to make a connection with another fax machine.</p>	<p>The other fax machine may be turned off, out of paper, or cannot answer incoming calls. Speak with the other machine operator and ask her or him to sort out the problem.</p>
<p>Documents are not stored in the memory</p>	<p>There may not be enough memory to store the document. If the display shows a "MEMORY FULL" message, delete any documents you no longer need from the memory, then restore the document.</p>
<p>Blank areas appear at the bottom of each page or on other pages, with only a small strip of text printed at the top.</p>	<p>You may have chosen the wrong paper settings in the user option setting. Refer to the Facsimile Reference to choose the proper paper size.</p>

NOTE





SPECIFICATIONS

This chapter includes:

- **General Specifications**
- **Scanner and Copy Specifications**
- **Printer Specifications**
- **Facsimile Specifications**

General Specifications

Item	Description
Printing method	Laser scanning unit
Scanning method	Sheet-fed and Flat-bed CCD(charge coupled device) module
Effective scanning width	8.2 inches (208 mm)
ADF Document size	Width 6.9 to 8.5 inches (174 to 216 mm)
	Length Single page: 5 to 59 inches (128 to 1500 mm) Multi pages: 5 to 14 inches (128 to 356 mm)
Recording paper type	for Tray : Letter, A4, Legal (weight: 60~90 g/m ² , 16 ~ 24 lb)
	for Bypass Tray: Letter, Legal, JIS B5, A4, Executive, A5, A6 card, Post Card 4x6, HagaKi, Envelope 7-3/4, Envelope COM-10, Envelope DL, Envelope C5 * Min.: 3.9 x 5.8 inches (98 x 148 mm), (weight: 60~120 g/m ² , 16 ~ 32 lb)
Recording paper capacity	for Tray : 550 sheets (weight: 75 g/m ² , 20 lb) for Bypass Tray: 100 sheets (weight: 75 g/m ² , 20 lb)
Automatic document feeder	Up to 30 pages (20 lb or 75 g/m ²)
Consumables	2-piece Toner/Drum cartridge system
PC Interface	IEEE 1284 Parallel, USB 1.1
Compatibility	Win 95, 98, 2000, NT 4.0, Win Me, Win XP
Power requirements	100 ~ 127 VAC, 50/60 Hz, 5A
Power consumption	Sleep mode: 35 W
	Standby mode: 90 W
	Average: 350 W
Operating conditions	Temperature: 50 °F to 89 °F (10 °C to 32 °C)
	Humidity: 20% to 80% RH
LCD	16 Characters x 2 lines
Toner cartridge life	6,000 pages (for starter, 3,000 pages) @ IDC 5% coverage
Drum cartridge life	15,000 pages @ IDC 5% coverage

Item	Description
SET Dimension (WxDxH)	22.0 x 17.0 x 18.1 inches (560 x 433 x 459 mm)
Weight	Net: 22.5 Kg (including consumables)
Package Weight	Paper: 2.7 Kg Plastic: 0.7 Kg

Scanner and Copy Specifications

Item	Description
Compatibility	TWAIN standard
Resolution	Optical 600 dpi resolution (Mono and Color)
Color bit depth	Internal: 32 bit External: 24 bit
Mono bit depth	1 bit for text mode 8 bit for Gray mode
Copy speed	15 copies per minute/A4 16 copies per minute/Letter
Copy resolution	1,200 dpi enhanced
Zoom Rate	by platen 25 ~ 400 % by ADF 25 ~ 100 %

Printer Specifications

Item	Description
Printing method	Laser Scanning Unit + Electro Photographic
Printing speed	15 copies per minute/A4 16 copies per minute/Letter
Print resolution	1200 dpi class
Emulation language	PCL 6

Facsimile Specifications

Item	Description
Printing method	Laser Scanning Unit
Compatibility	ITU-T Group 3, ECM
Applicable line	Public Switched Telephone Network(PSTN) or behind PABX
Data coding	MH/MR/MMR (ECM Mode) and JPEG for color fax transmission
Modem speed	33600/28800/21600/19200/14400/12000/9600/7200/4800/2400 bps with fall back
Transmission speed	Approx. 3 seconds/page * Transmission time applies to memory transmission of text data with ECM compression using only ITU-T No.1 Chart.
Scanning speed	Platen: approx. 3 seconds/letter (at standard fax resolution mode) ADF: approx. 5 seconds/letter (at standard fax resolution mode)
Resolution	Standard(203x98 dpi), Fine(203x196 dpi), Superfine(300x300 dpi), Photo(203x196 dpi/300x300 dpi), Color(203x196 dpi)
User Memory	4 MB (320 pages)
Halftone	256 levels
Auto dialer	One-touch dialling (registration for 40 numbers) Speed dialling (registration for 80 numbers)





INDEX

A

ADF load 4.3

C

cartridge locking lever 1.14

clone

 in copy mode 4.10

collation for copying 4.12

contrast

 for copying 4.7

copy size 4.8

D

default printer 5.2

display language 1.19

document

 jam, clear 8.2

 load in ADF 4.3

 load on document glass 4.4

document glass

 clean 7.2

 load 4.4

drum

 clean 7.8

 install 1.12

 replace 7.8

E

error 8.11

extension phone, connect 1.10

F

fit to page

 print 5.8

fit to page print

 in copy mode 4.9

G

graphic properties, set 5.17

J

jam, clear

 document 8.2

 paper 8.4

L

Loading Paper in the Tray 3.1

N

network printer, set 5.20

n-up (multiple pages per sheet)

 print 5.6

O

overlay, use 5.13

P

paper jame, clear 8.4

paper load

in Bypass tray 3.6

in Tray 1.15

paper load capacity 3.2

paper save 1.20

paper size, set

in Bypass tray 3.9

paper source

in copy mode 4.2

in print mode 5.5

paper type 3.2

parallel, connect 1.11

poster

print 5.9

power save 1.20

print resolution 5.17

printer driver

install 2.4

printer driver window 5.3

printing

fitting to a selected paper size 5.8

multiple pages on one sheet 5.6

posters 5.9

reduced or enlarged document 5.7

using overlays 5.13

watermarks 5.10

R

reduced/enlarged

print 5.7

S

Safety information 1.vi

scanner lock 1.2

software

install 2.4

T

tel line, connect 1.9

toner cartridge

install 1.12

life 7.3

replace 7.5

two-sided print

in copy mode 4.11

Type 102 driver

install 2.4

U

USB, connect 1.10

Using the Bypass Tray 3.1

W

watermarks, use 5.10

